

FROM GRAIN ELEVATOR TO CREAMERY

RECONNECTING TO THE WORKING LANDSCAPE IN SILVANA, WASHINGTON

Grace Crofoot

a thesis

submitted in partial fulfilment of the
requirements for the degree of

Master of Architecture

University of Washington

2013

Reading Committee:

Gundula Proksch, Chair

Elizabeth Golden

Rick Mohler

Program Authorized to Offer Degree:

Architecture

© Copyright 2013

Grace Crofoot

TABLE OF CONTENTS

FIGURES	ii
INTRODUCTION	I
Proposal	4
Rationale	4
THEORETICAL FRAMEWORK	7
Rural Environments, Built Environments	7
Landscapes of Work	8
Grain Elevators - Utilitarian Storage and Cultural Symbol	12
METHODOLOGIES	18
PRELIMINARY FINDINGS	20
DESIGN RESPONSE	56
CONCLUSIONS	86
APPENDIX A - PRECEDENT STUDIES	88
REFERENCES	96
IMAGE REFERENCES	98

FIGURES

1	Aerial view of Silvana, 1964	2
2	Silvana Grain Company Building, approach from south	5
3	Silvana farmland	6
4	Folk Art painting, unknown artist	8
5	“Classic Landscape,” Charles Sheeler	8
6	Farm grid in Iowa	9
7	Industrial farm buildings	9
8	CSA farm in Carnation, Washington	11
9	Grain elevator typologies	13
10	Silvana Grain Company Building, with field, rail, town	13
11	Grain elevator diagram	14
12	Partially dismantled cribbed timber elevator	17
13	Silvana Grain Company Building, in the working landscape	19
14	Barn as nostalgic symbol	20
15	Church as nostalgic symbol	20
16	Juxtaposition of pastoral mural and industrial grain elevator	21
17	Historic view overlooking Stillaguamish River, 1915	22
18	Historic view of logging truck and storefronts in Silvana, 1915	22
19	Connections to urban centers	24
20	Encouraging local food communities	25
21	Connections to local farms	26
22	Silvana Fair logo	28
23	Harvest Jubilee logo	28
24	Map of Silvana	29
25	Flooding in Silvana	30
26	Silvana Grain Company Building, overall	31
27	Site analysis	32
28	Site map	33
29	Remnants of painted advertisement	35
30	Comparison of grain elevator construction types	37

31	Construction sequence & structural qualities, part 1	39
32	Construction sequence & structural qualities, part 2	41
33	Construction sequence & structural qualities, part 3	43
34	Construction sequence & structural qualities, part 4	45
35	Program diagram	47
36	Artisan cheese making process diagram	48
37	Handmade Gouda cheese from Holland	51
38	View of proposed facility	57
39	Program placement diagram	58
40	Exterior interventions series	40
41	Exterior cladding materials	63
42	Interior interventions series	64
43	Primary visitor sequence diagram	66
44	Ground floor plan	68
45	Second and third floor plan	69
46	View of approach	71
47	View of entry space	73
48	View of aging tower	75
49	View of cheese tasting classroom	77
50	View of bin tasting room	79
51	Section through cheese making classroom	80
52	Section through tower	81
53	Long section through building	82
54	Section through entry and aging tower	83
55	Section through creamery	84
56	View of proposed facility at night from across the fields	86
57	Silvana Grain Company Building, in town context	89
58	Marmelo Mill, delivery space	90
59	Marmelo Mill, transparency of process	90
60	Marmelo Mill, of the working landscape	91

FIGURES CONTINUED

61	Novelty Hill Januik Winery, from tasting to barrel storage	92
62	Novelty Hill Januik Winery, from barrel storage to tasting	92
63	Willapa Hills Creamery, milk tank	94
64	Willapa Hills Creamery, dishwashing station	94
65	Willapa Hills Creamery	95
66	Silvana Grain Company Building	100

The author would like to thank Louisa larocci for helping to conceive of this thesis, and Gundula Proksch, Elizabeth Golden, and Rick Mohler for helping to make it happen. Thank you to my classmates for believing in my abilities. Finally, thank you to my family, friends, and most especially my husband, for your love, support and acceptance of my general absence for the past six months.



[INTRODUCTION]

Rural agricultural landscapes make up most of the land area in the United States and are the source of most of our food, yet they are not often part of architectural discourse. Dismissed as either purely utilitarian, or conversely as nostalgic backwater, agricultural landscapes are overlooked as a subject of design intervention. Even with the current trend of urban agriculture, the original site of farming—the rural site—is largely left out of the discussion. Spatially and mentally disconnected from people in cities, rural landscapes have lost their meaning as places of work and as the source of most of our food. Distorted perceptions of where our food comes from results not only in unhealthy eating habits, but also leads to huge energy consumption in transporting food across the globe.

Understanding rural farmland as a working landscape as opposed to a pastoral ideal is an essential step in reconnecting with the realities of food production and modern agriculture. This thesis posits that architecture can play a role in restoring the agricultural landscape as a place of work and exchange, and by locating a food processing facility directly adjacent to the land which produces its raw material, a connection can be made between the work done on the land and the food that we eat. This thesis responds to the out-of-sight, out-of-mind mentality regarding modern farming, with the intention that agricultural landscapes can be revealed as meaningful sites through their connection to a culture of local food production.

1. Aerial view of Silvana, Washington - a rural built environment

PROPOSAL

This thesis explores these ideas through the lens of an adaptive reuse project which converts an obsolete grain elevator in the small town of Silvana, Washington into a small-scale artisan creamery. As the grain elevator is located directly in the working landscape where the cows are raised and the milk is produced, a strong connection between the food and its origin is established. By creating a place where connections can be made between the local farmland and the production of food, people can be encouraged to eat more healthily and to buy locally.

RATIONALE

The building to be reused, the Silvana Grain Company Building, has a prominent presence due to its height and location within the small town. This prominence makes the building a powerful potential sign and symbol with which to champion the new creamery. By capitalizing on the varied structural systems and unique spaces within the grain building, a multi-sensory and interconnected experience can be created as one moves through the building. Furthermore, the building was once intimately tied to grain, the major cash crop in the region. But today dairy farming dominates the valley's agricultural output, which suggests a corresponding change in function for the Silvana Grain Company Building. While before the building served for the storing and processing of grain, now it will house the collection and processing of milk into cheese. By introducing a program that represents the trend towards local, artisanal food production, and by expressing this use in a way that makes it visible and available to the public, this thesis seeks to explore a new architecture of rural farming and food production.

2. Silvana Grain Company Building





[THEORETICAL FRAMEWORK]

RURAL ENVIRONMENTS, BUILT ENVIRONMENTS

Agricultural landscapes, from the cultivated fields to the barns to the grain elevators, are built environments, shaped by humans from the natural landscape. Though most of the decisions about how to alter these landscapes derived from utilitarian reasons—the production of food—they also take on cultural meaning by making visible the human imprint on the land. As such, it is as viable and productive to address issues surrounding sustainable food practices via design here as in a suburb, city, or other human settlement.

In order to fully inform the project, the site must be analyzed at a range of scales. This effort begins at the broadest scale of the landscape, in this case, at the scale of a farming community. The analysis then moves in to the scale of the building, examining a grain elevator as a node in the network of production within the farming community. Finally there is the scale of the material to be processed, and its movement through the building, as well as its relationship to human users during production and exchange.

3 Fields, fences, barns and outbuildings form the built environment in Silvana, WA

LANDSCAPES OF WORK

Agricultural landscapes have always been, by definition, landscapes of work. No longer natural, they are shaped by people into productive land. Agricultural landscapes are as much a built environment as any town, suburb, or city. Like any built environment, there are layers of human occupation built upon the natural features of the land.

As much as they are physical places, rural farmlands also embody a set of ideas that form an image that influences our perceptions of them as landscapes. Landscape architect Sally Schauman discusses this idea in the article, “The Garden and the Red Barn: The Pervasive Pastoral and Its Environmental Consequences.” As she writes, pastoral imagery is deeply embedded in the American vision of agricultural landscapes. The pastoral ideal envisions rural farmland as an idyllic, romantic landscape, a place to live out a slow-paced, American “good life.” Common icons within this imagery include rolling fields, white picket fences, and of course, red barns (Fig. 4). Patriotic songs, American literature, even modern advertising reinforces this imagery in our collective psyche. While seemingly charming and harmless, this nostalgic imagery masks the realities of modern, industrialized farming (Fig. 5). As a result, rural places are largely ignored by architects as valuable opportunities for design innovation, while the public ignores the huge environmental impact of modern farming.¹ While this rural imagery is an important part of American culture and should not be erased, it is important to challenge the assumptions it generates. This pervasive image of pastoralism masks the complexities of modern agriculture, both good and bad. Agricultural landscapes can be appreciated in much more depth than as simply scenery.

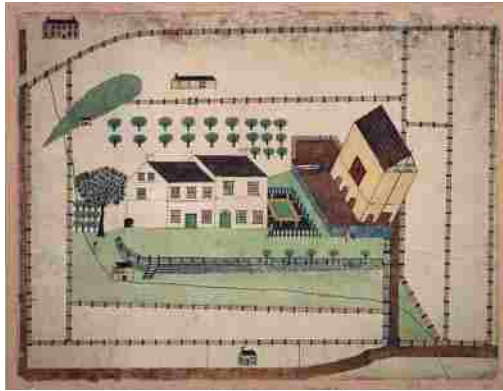

4. Folk Art painting by unknown artist showing pastoral ideals



5. “Classic Landscape” by Charles Sheeler showing an industrial farming scene

¹ Schauman, Sally. “The Garden and the Red Barn: The Pervasive Pastoral and Its Environmental Consequences.” *The Journal of Aesthetics and Art Criticism*, 1998: 181-190.

Allen Carlson, a philosopher studying environmental aesthetics and ethics, examines the aesthetic value of modern farmland in his article, “On Appreciating Agricultural Landscapes”. He argues for the appreciation of modern agricultural landscapes, which, he argues, follow many principles celebrated in modern design such as clean lines, clear order, and of course, form following function.² However, this admiration for the cultivated landscape must be tempered with critical analysis. Modern agricultural practices present a similar moral dilemma to the building industry in having to balance economic goals and environmental impacts. Though we as architects can appreciate the aesthetics of a concrete building, we must also acknowledge the carbon footprint and ecological ramifications of using this building material. In the case of farming, the widespread use of harmful pesticides causes pollution, irresponsible irrigation practices cause drought, over-farming causes soil erosion, and monoculture crops threaten biodiversity.³ The wide range of problems caused by industrialized agricultural practices is undeniably complex; the drive to produce more food per acre is driven by a need to feed our growing population as well as produce a profit. While taking on the entire system of industrialized agribusiness is beyond the scope of this thesis, it can certainly shed light on the subject.



6. Highly regular grid of farms near Slater, Iowa



7. Industrial farm buildings utilize simple forms, rhythmic structural grids, and modern materials

2 Carlson, Allen. “On Appreciating Agricultural Landscapes.” *The Journal of Aesthetics and Art Criticism* (Wiley) 43, no. 3 (Spring 1985): 307-308

3 Solbrig, Otto T., Robert Paarlberg, and Francesco di Castri. *Globalization and the Rural Environment*. Cambridge, MA: Harvard University Press, 2001: 124-135.

A major reason that agricultural landscapes are so easily dismissed and generally misunderstood is the simple fact that today very few people have any contact with farming of any kind. The former connection that came from cultivating the land is largely gone. Cultural geographer David Lowenthal writes about this lack of connection to the land in his article, "European Landscape Transformations: The Rural Residue". In just a few generations, we have shifted from an almost entirely agrarian population to one that is almost entirely urban. As a result, our understanding of agriculture as a culture of work is limited, and rural landscapes have lost their meaning. Lowenthal writes, "the country is [now] a place for living, not making a living".⁴ To counter this disconnection, this thesis sites the project directly in the agricultural landscape of Silvana, Washington. A facility which marries a finished product to its place of origin will foster a new connection to rural farmland in western Washington.

Historian Richard White examines the relationship between humankind and nature present in the Columbia River's landscape in his book, *The Organic Machine*. His idea that nature can be known through labor is directly applicable to agricultural landscapes. White posits that by catching a salmon, a person can come to know it, or by damming the Columbia River and harnessing its power, the people who worked there came to know the river.⁵ Thus, by cultivating the land, as he writes, "the human and natural, the mechanical and the organic, had merged so that the two could never be ultimately distinguished."⁶ Through the

4 Lowenthal, David. "European Landscape Transformations: The Rural Residue." In *Understanding Ordinary Landscapes*, edited by Paul Groth and Todd W. Bressi, 180-188. New Haven: Yale University Press, 1997, 183.

5 White, Richard. *The Organic Machine: The Remaking of the Columbia River*. New York: Hill and Wang, 1996, 34-35

6 White, 108.

labor that connects us to the land, the land becomes both natural space and social space.⁷ By thinking of agricultural landscapes in this way, as landscapes of work, as landscapes where human and natural have merged, we can come to a deeper understanding of our rural environments.



8. Locals gather food at a Community Supported Agriculture (CSA) farm in Carnation, WA, a rare opportunity for many Americans. Photo by Ellen M. Banner, Seattle Times

GRAIN ELEVATORS: UTILITARIAN STORAGE AND CULTURAL SYMBOL

Like the landscapes in which they sit, grain elevators exist as physical artifacts of agriculture practices, but also as cultural symbols of farming towns. This significance is much more place-based than the fetishizing of these industrial structures by early Modernist architects. Rather than being just an impressive object, the grain elevator would have been an important node in the community, its height and presence symbolizing the town's success.

In the early twentieth century grain elevators became an object of fascination for European architects. In the writings of Walter Gropius and Le Corbusier, they were celebrated as pure geometric forms that were the emblems of modernity, “the magnificent first-fruits of the new age”.⁸ The utilitarian structures continued to inspire artists and photographers who sought to portray formal examples of modernism. As Aldo Rossi writes in introduction to the book *Grain Elevators* by Lisa Mahar-Keplinger, found truth and architecture in the grain elevators across the United States. As demonstrated in the book, the grain elevator is a quintessential example of form following function, and the forms that result are undeniably clean, powerful, and expressive. However, Mahar-Keplinger's work also continues the fetishization of the grain elevator as an object. Even as she briefly describes their purpose in a larger network of grain collection and distribution, the photography of the individual elevators emphasizes their presence as individual objects.⁹ But the book convincingly illustrates that grain elevators are an important architectural typology: much more than a sculptural object, they are working, utilitarian buildings, intimately connected to their landscapes of work.

“THE ELEVATOR WAS NOT A MONUMENT BUT A PROCESS”

-George O. Carney

9. Typology photographs fetishize the grain elevator as an object
10. The Silvana Grain Company building in the context of the fields and the town.

⁸ Corbusier, Le. *Towards a New Architecture*. London: The Architectural Press, 1923, 33.

⁹ Mahar-Keplinger, Lisa. *Grain Elevators*. New York: Princeton Architectural Press, 1993.

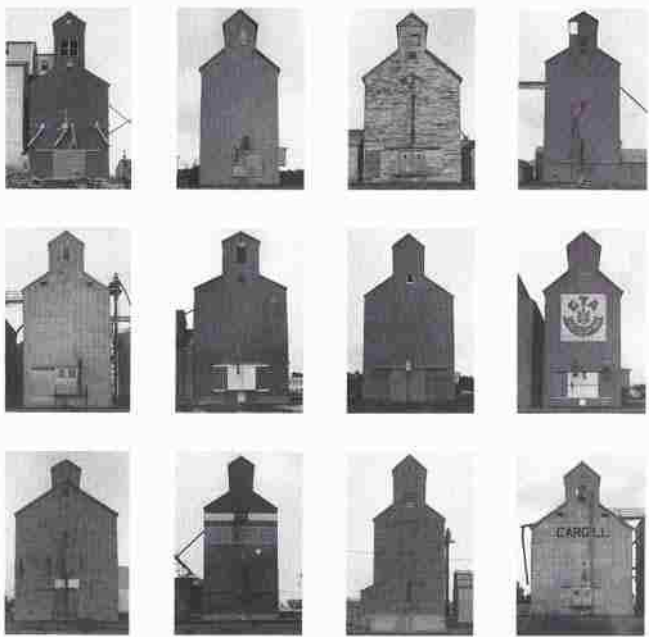

11. Typical grain elevator mechanics

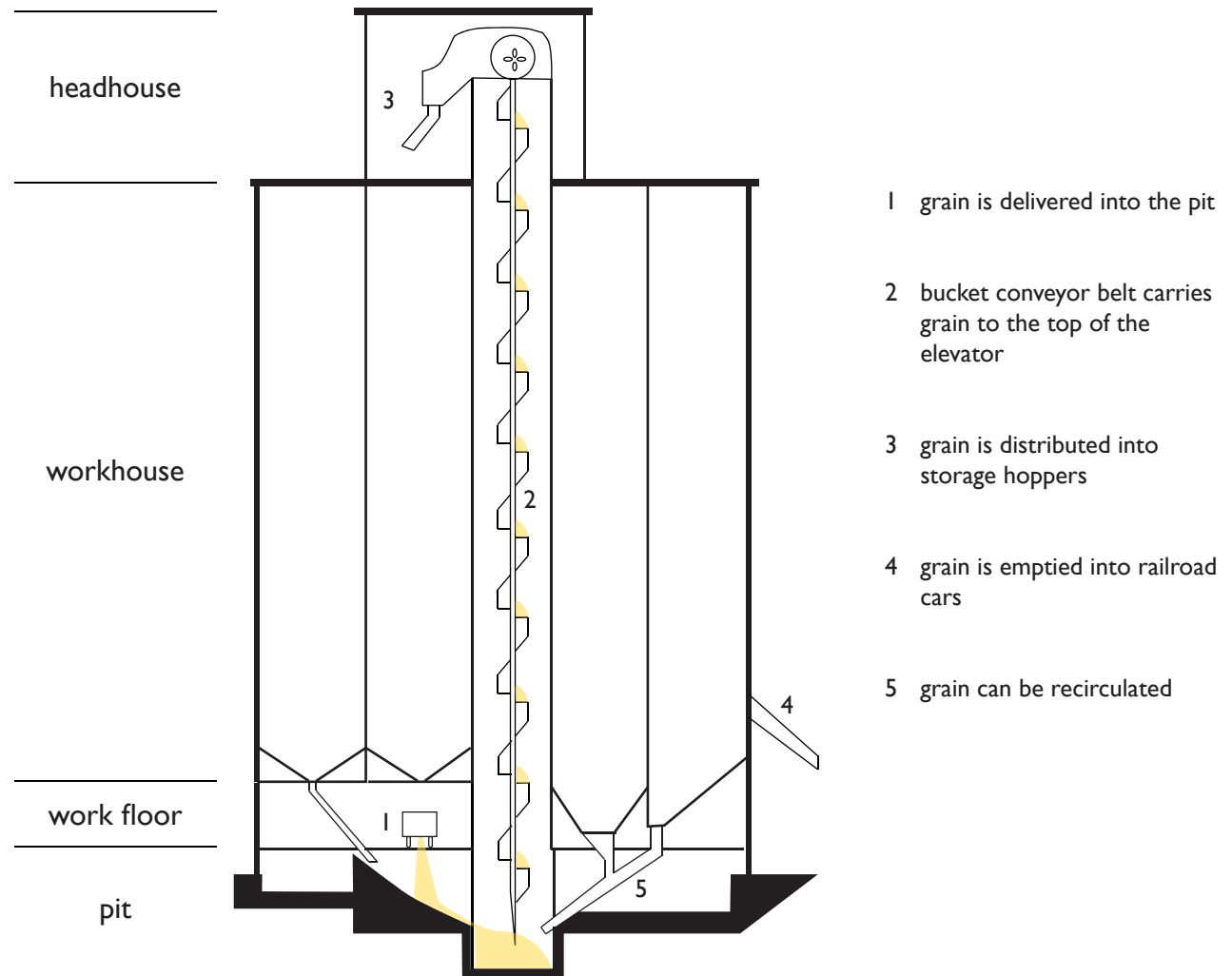

Cultural geographer George Carney writes about the workings of grain elevators, both in terms of their internal function and the way they operate as part of a larger infrastructure of the production and distribution of grain. By lessening the attention to their monumental appearance, he directly challenges the more poetic notions put forth by Modern architects. His focus is on the utilitarian role these structures played in the industrialization of agriculture in America and Canada, as engineered to work to make the growing of grain more profitable. Carney describes how grain elevators were built across the United States during the early 1900s as machines for the collection, storage, and distribution of grain. He explains their height in terms of engineering; grain is most efficiently stored in vertical bins. Small grains have interesting static properties, acting as neither solids nor liquids. As a result, when stored vertically, the friction between the individual grains creates an arching effect which partially transfers gravity forces to the bin walls. Also, the use of simple machinery to lift the grain into the vertical hoppers allowed the dispensing of the grain to be done using gravity. In a horizontal configuration, much more manual labor is required.¹⁰

¹⁰ Carney, George O. "Grain Elevators in the United States and Canada: Functional or Symbolic?" *Material Culture* 27, no. 1 (Spring 1995): 1-24.

Architects Robert Hutchison and Taiji Miyasaka write about timber grain elevators in eastern Washington and their potential for reuse. First, they point out that in their singular use as a place to storage grain, they are inherently intended for only the most limited human occupation. This, along with their rigid structures, make them difficult to adapt to new uses. However, as they also point out, they are “embodied with opportune material value.”¹¹ While this has often meant that the elevators are simply stripped down for reclaimed material to be used in other projects, it also can justify their reuse in place. As a hybrid structure, the Silvana Grain Company Building is more flexible than simple grain elevators, and so offers a rare opportunity to bring people into a new relationship with a formerly unoccupied structure.

The role of the grain elevator as an efficient machine for the storage and distribution of grain reveals the inner workings of the sculptural exteriors that drew the attention of modernist architects. In examining the Silvana Grain Company grain elevator, this thesis seeks to understand this structure as a part of its larger context in the agricultural landscape, and as an example of this building typology, as both processing facility and cultural symbol.

11 Hutchison, Robert, and Taiji Miyasaka. “Timber Grain Elevators.” *Column 5 Journal of Architecture* (University of Washington Department of Architecture) 23 (2009).



12. Partially dismantled cribbed timber elevator in Garfield, WA

[METHODOLOGIES]

This thesis seeks to confront issues surrounding designing in a rural context by first understanding the agricultural landscape as a place of work, where human- and nature-made layers intertwine to create a built environment. By challenging the pastoral imagery associated with agricultural landscapes, and by understanding grain elevators as more than sculptural objects and rational machines, a nuanced solution can be reached. Specifically by exploring architectural solutions which highlight local, sustainable food and farming practices, progress will be made towards reestablishing the land as a place of work and exchange.

The design is a response to site conditions, seeking ways to reconnect this infrastructural node with its working landscape. By integrating this project into the town's commercial center, creating visual connections to the surrounding farmland, and by actually sourcing milk from local farms, the new facility will be deeply connected to the local community. The proposal for a creamery derives from the desire to reestablish the Silvana Grain Company Building's connection to current local agricultural production, which has shifted from grain to dairy. Furthermore, an artisanal food manufactory complements the current trend towards cooperative, small-scale, sustainable farming practices.

This thesis seeks to maintain a specific attitude concerning the adaptive reuse of the Silvana Grain Company Building. This is not intended to be a preservation or restoration project. Instead, the new intervention will be treated as a new layer to be added to the history of the building. As John R. Stilgoe writes in his book, *Outside Lies Magic*, "...



13. Silvana Grain Company Building as a part of the landscape

the built environment is a sort of palimpsest, a document in which one layer of writing has been scraped off, and another one applied.”¹² The key to successful adaptive reuse is to capitalize on the existing building’s strengths and minimize any weaknesses, while optimizing the space for the new intended function. By conducting a thorough analysis of the existing structural conditions and spatial qualities, a strategy can be devised to both take advantage of the building’s unique yet functional spaces and simplify any awkward conditions in order to best accommodate the new function of a creamery. The grain tower in particular presents an opportunity to bring people into a new relationship with a formerly unoccupied structure. Effort will also be put towards maintaining the building’s utilitarian and symbolic identity, but to enhance and update its appearance to reflect its new human-oriented use.

¹² Stilgoe, John R. *Outside Lies Magic: Regaining History and Awareness in Everyday Places*. New York: Walker and Company, 1998.

[PRELIMINARY FINDINGS]



14. This barn, as an accepted agrarian symbol, is regularly painted by local people.



15. Well-loved buildings, like the historic church, are well marked.

SILVANA, WASHINGTON

Elements of agriculture as both an industrial pursuit and a pastoral ideal are very visible within the town. Across the street from the near-abandoned grain elevator is a mural on the side of the antique shop portraying green fields and pastures divided by white picket fences, horse-drawn wagons, a white farmhouse and a red barn. The juxtaposition of the industrial grain elevator and the nostalgic mural serves to illustrate the tension between traditional and modern agricultural practices. The grain elevator has a long history in the town, and was clearly tied to the town's success as a farming community, but more importance is still given to the more easily identifiable components of pastoral imagery: the small local church, and of course the barn.

By creating a new food facility which engages the public, an opportunity is created to teach people the value of local, handmade food in an highly visible way. While activities like this are already present within the town, this new project can connect with and thus activate these local businesses, creating a network of local food which will become a stronger presence within the town.

16. Juxtaposition of pastoral mural and industrial grain elevator in Silvana





17. Historic view ca. 1915 overlooking Stillaguamish River



18. Historic view ca. 1915 of logging truck in front of main Silvana storefronts

During the early settlement of western Washington, the leading crops were potatoes, oats, and wheat.¹³ The Stillaguamish River Valley was logged in the 1880s, which cleared the land for farming. Early cash crops for the region included hay and oats. In 1891 the Seattle & Montana Railway, controlled by the Great Northern Railway, came to the Stillaguamish Valley, connecting the region to Seattle in the south and Bellingham in the north.¹⁴ In recent years, dairy farming has become the dominant land use, as opposed to grain production.

¹³ University of Washington Libraries. Washington History of Agriculture. n.d. <http://harvest.mannlib.cornell.edu/node/35> (accessed June 09, 2013).

¹⁴ Prasse, Karen. "Stanwood - Thumbnail History." HistoryLink.org: The Free Online Encyclopedia of Washington State History. April 5, 2008. (accessed January 28, 2013).



19. Silvana, WA, has the potential to draw tourism from regional urban centers

Silvana, Washington is located about 45 miles north of Seattle in the flood plain of the Stillaguamish River. Part of the intention of this thesis is that this facility could become part of a local food community on both regional and local scales. It has the potential to draw tourism from the nearby urban centers of Seattle as well as Vancouver, B.C., both of which have active communities of people interested in local and artisanal foods.

This facility also could be a key part of building a sustainable local food community with the various organizations, farms, and food artisans in the region. Skagit River Valley, located north of the Stillaguamish River Valley has created a vibrant agriculture based community, This thesis contends that The Stillaguamish River Valley could do the same.



20. The new facility will be part of a regional local food community

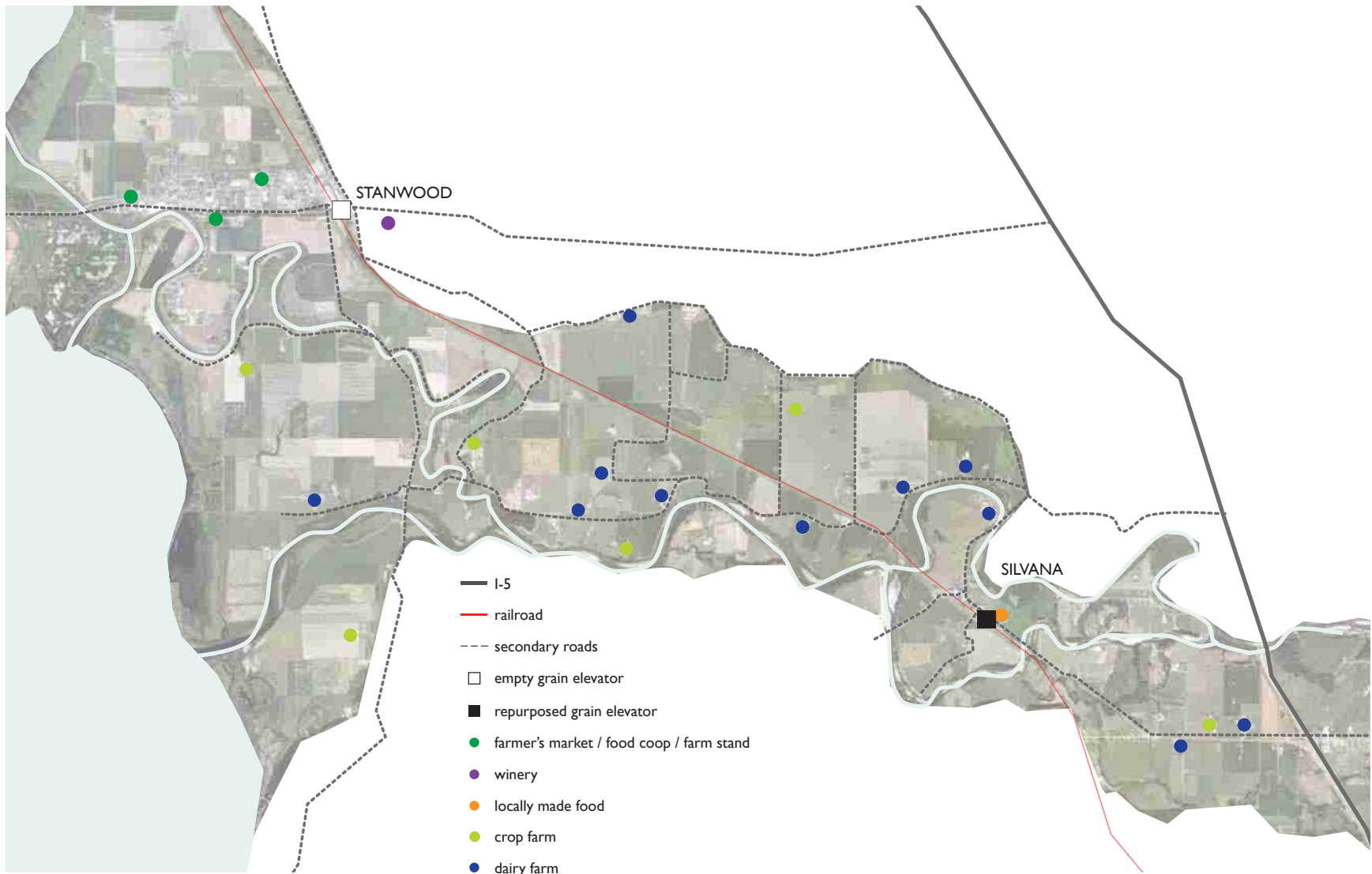

As seen from an aerial view, the Stillaguamish River runs through the valley, a snaking line through the patchwork fields, all bounded by the treed bluffs to north and south. Surrounded by farms, the town is located at the meeting point of Pioneer Highway—the main road through the valley—and the railroad. The layers of human intervention — the land artificially divided into fields for different crops, the farmsteads and outbuildings marking different areas of living and working, the network of roads connecting the farms, the railroad cutting across the center — are all evidence of this working, built environment. The landscape is a merging of natural and human intervention, a machine for the production of food, but still a desirable place to live and work.

On the local scale, the creamery can source its milk from these local dairy farms, and connect to other local agriculture and organizations which are starting to appear in the area, particularly in the community of Stanwood to the north. For example, the Port Susan Food and Farming Center, founded in 2010, is a local organization that supports “a viable food and farming community,” with a focus on value-added and niche-market agricultural products. Located in Stanwood, the town immediately north of Silvana, the Center organizes tours of farms in Stanwood, Camano Island, and Silvana, and runs a farmer’s market during the summer and fall months.¹⁵ By capitalizing on this new but enthusiastic support network the creamery can be a highly successful venture.

21. The creamery can source its milk from local farms, and become part of a local food community in the Stillaguamish River Valley

¹⁵ Port Susan Food & Farming Center. Our Mission. 2013. <http://www.portsusan.org/about/> (accessed June 12, 2013).



22. The Silvana Fair is an annual event, held in town directly across from the site, which celebrates local farming

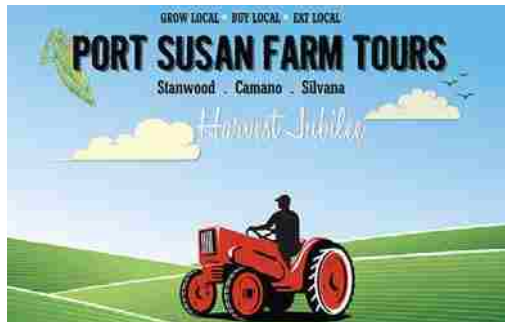

23. The Harvest Jubilee, sponsored by the Port Susan Food and Farming Center, hosts several farm tours in Stanwood, Camano Island, and Silvana.

The small agricultural community of Silvana is a typical example of a western Washington farming town. The total population of Silvana is 90 people, according to the 2010 census.¹⁶ Local businesses include several farms (dairy, grass-fed beef), a small café, two retail storefronts, a small convenience store, and Silvana Meats, a local butcher shop. Town amenities include a local church, a fire station, a post office, a small town square, and a community hall.

The beginnings of a local food community already exist in Silvana and neighboring Stanwood. Local businesses like Silvana Meats and Klesick Farms already participate in sustainable food practices. Community events, like the annual Silvana Fair and the Harvest Jubilee, celebrate farming. This new facility can immediately become an active participant, provide new spaces for events, and further activate interest in the community.

¹⁶ U.S. Census. "Census 2010 Table DP-1." 2010. <http://factfinder2.census.gov/> (accessed July 11, 2013).



24. Town of Silvana, WA. Note the Silvana Grain Company Building's location in the commercial center of town, between the primary road and the railroad.



25. Flooding in Silvana

The Stillaguamish valley is subject to frequent flooding, usually in the months of November and December. During a flood event, several inches if not feet of water fill much of the valley.¹⁷ While the flood waters bring nutrients to the fields, they are also a threat to people, livestock, stored crops, and buildings. For protection, buildings in the valley are raised on high foundations or are sited on high points in the landscape. For example, the Silvana Grain Company Building has raised floors throughout two thirds of the building, keeping any stored items safely above flood water levels. The same forces that bring life to the agricultural economy are also a potential force of destruction; the river should be celebrated and respected.

Silvana is a town which is ripe with potential for food-related expansion. Interest in specialty handmade foods is already growing in the community. Due to its proximity and connections to larger markets like Seattle, it also has the potential to be a successful supplier of artisan cheese to the region. Furthermore, it is home to the Silvana Grain Company Building, which can be the ideal structure for grounding this new facility to its community.

26. Silvana Grain Company Building, prominently sited along the road

¹⁷ Snohomish County. "Chapter 5 - Flood History." Surface Water Management Division: Stillaguamish River Comprehensive Flood Hazard Management Plan. February 2004. http://www.l.co.snohomish.wa.us/Departments/Public_Works/Divisions/SWM/Library/F-StillyRivCompFloodHazMgmtPlan-2003.htm (accessed June 11, 2013).



27. Map of Silvana, showing the Silvana Grain Company Building sited at the confluence of town and field, road and rail



SILVANA GRAIN COMPANY BUILDING

This building is an advantageous location for this thesis proposal, both physically and symbolically. For its meaningful historical ties to the agricultural economy of the region, and for its position as a node in the collection, processing, and distribution of local food, it lends meaning to the site and the program. Due to its original purpose as a grain elevator, the Silvana Grain Company Building is ideally sited at the confluence of the cultivated landscape, the commercial center of the small town, and the meeting of transportation infrastructure, both road and rail. The building occupies a very long and narrow site, bordered by Pioneer Highway to the northeast and the railroad to the southwest. As such, it has a very long street frontage on the main road through town. To the northwest, a large gravel lot occupies the space between road and rail, while to the southeast a narrow field fills the space.



28. Site map

The Silvana Grain Company Building was an important node in the Lower Stillaguamish River food production network. It can be classified as a local, or country, elevator.¹⁸ This made it the first commercial link between local farms and larger markets. The need for such large quantities of storage arose when grain production increased such that farmers could not affordably store it on site. Furthermore, elevators increased the efficiency of selling and transporting the grain, increasing profits for farmers.¹⁹ The Silvana Grain Company Building thus acted as a collector of all of the local farmer's grain, storing it in its monumental silo, and then distributing it to trains on their way to market. The elevator was a place of storage as well as a distribution point, holding then releasing the grain according to market values. Eventually, when the large sheds were added to the elevator structure, some grain processing occurred on site, as is evident in the painted advertisement. (See Fig. 29) Grain elevators frequently incorporated initial grain cleaning and sorting, and some even included flour mills for complete processing before shipping.²⁰

Though dated to 1900 by local historians, historic photos suggest the building was built sometime after 1915. While the primary construction method of the grain elevator itself places it before 1930, it is clear from the varying construction types that this hybrid structure was built in phases. Two large shed structures were added to either side of the tower at two separate subsequent dates. This accretion over time, as well as its structural system and asymmetrical, idiosyncratic form, indicate that it was built by local builders.²¹

18 Carney, 11.

19 Carney, 12.

20 Hayes, Brian. *Infrastructure: A Field Guide to the Industrial Landscape*. New York and London: W.W. Norton & Company, 2005.

21 Carney, 3.

Although the grain elevator function is now obsolete in this community, the large flexible spaces in the sheds have allowed the building to remain in use. It is currently used as storage for a company which restores WWII airplanes. The central tower is left largely empty, while the sheds have been stocked with large scale shelving units.



29. Remnants of a painted advertisement, now found on the interior of the building

The Silvana Grain Company Building is a hybrid utilitarian structure, not purely a grain elevator. While the central tower did in fact store grain and served as a place of exchange between the local farms and markets reached by train, the additional shed space on either side housed additional functions. The tower contains 5 intact bins with hoppers, and the open shaft for the elevator leg, arranged in a 2x3 configuration, all accessible from the second level. One larger bin which reaches to the ground floor.

At the ground floor, large sliding doors open to the main street to receive goods from farmers, and to the railroad to load product onto a train for delivery. On the street side, a raised loading dock allows for easy transfer from trucks. On the rail side, the remains of an overhead crane loading system remain. Other sliding doors open along the back, elevated above the ground, suggesting that there once was a train platform. This porosity across the transverse section is indicative of its primary function as a place of transfer. The building's construction system can be classified as a iron-clad cribbed construction type.²²

30. Comparison of Silvana Grain Co. Bldg. and a typical iron-clad cribbed construction elevator

²² Mahar-Keplinger, 19.

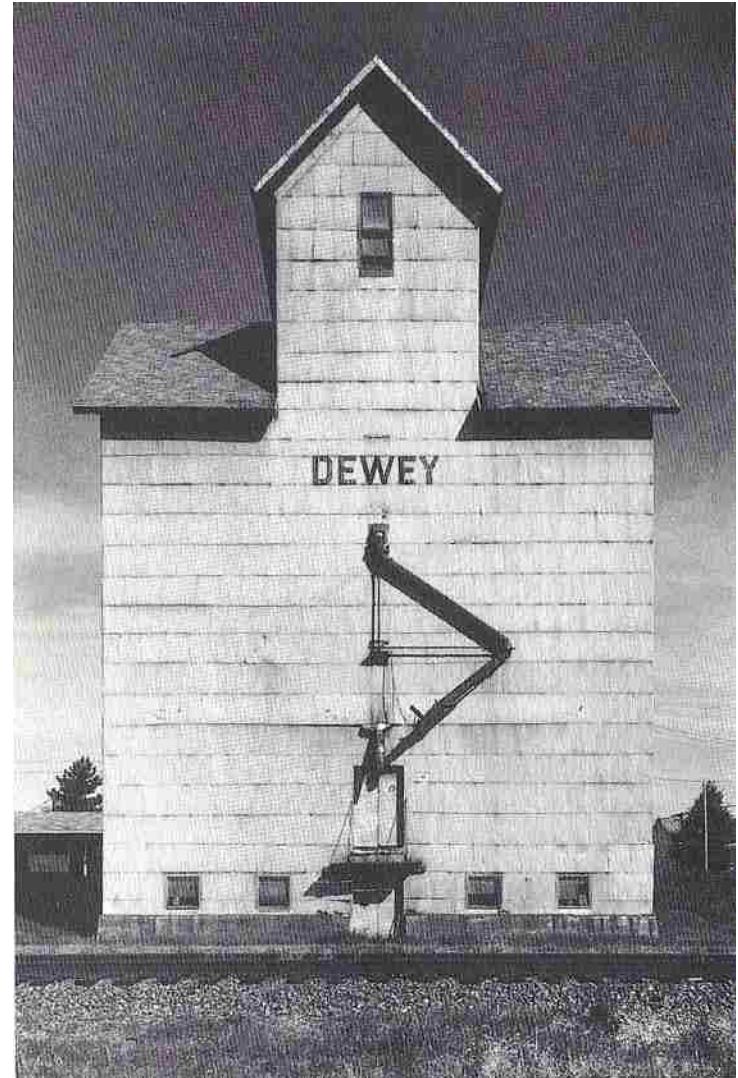

The existing building can be seen as a rudimentary system of skin and bones . The bones start to create the framework for unique spaces, while the current bare minimum skin helps define the recognizable grain elevator and agricultural shed typologies. So, as we start to break down the existing building, we can see that the various sections that were built over time have various distinct wood construction, beginning with a heavy timber system in the original tower. The bins are built using the cribbed construction technique, which is what gives this elevator that classification. This means that 2x6 lumber is stacked one on top of another and fastened together at each level, giving the strength needed to resist the lateral loads of the grain. The tower rises to about 65 feet at its highest point.

31. The tower was built first using a combination of heavy timber framing and cribbed bin construction

ca. 1920

ORIGINAL TOWER

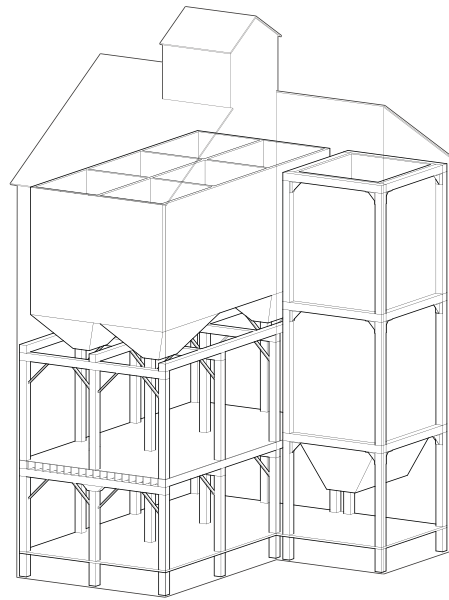

The following shed structures were built with light wood truss systems, which create predefined zones which are used in the design proposal to help organize the program and the flow of people and goods. The first shed addition to the northwest of the tower is characterized by closely spaced wood trusses, built at two feet on center. The trusses create a dynamic field of wood overhead and span 40' to create a large flexible space within.

32. The first shed addition has a column-free space spanned by densely packed timber trusses

ca. 1920
ORIGINAL TOWER

1927
1ST SHED

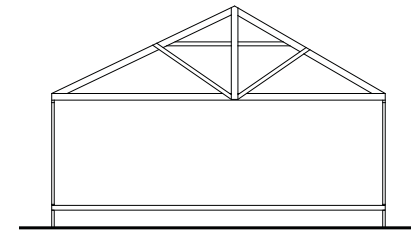

40' SPAN

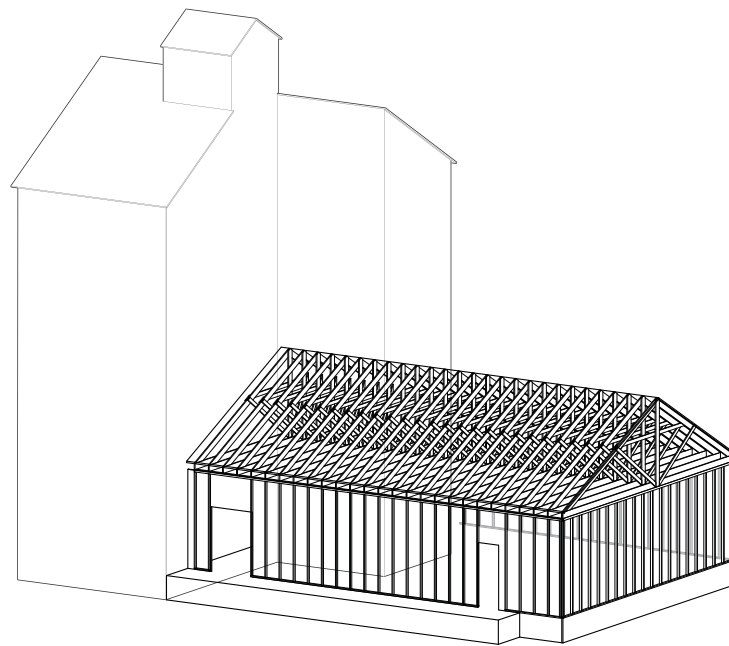

The second addition is a second light wood framing system, with columns spaced at eight to ten feet apart. This less flexible space can nonetheless provide plenty of storage, which is a crucial function in the creamery. Together, the two north sheds are about 85 feet long.

33. The second shed addition roof is supported by wood columns

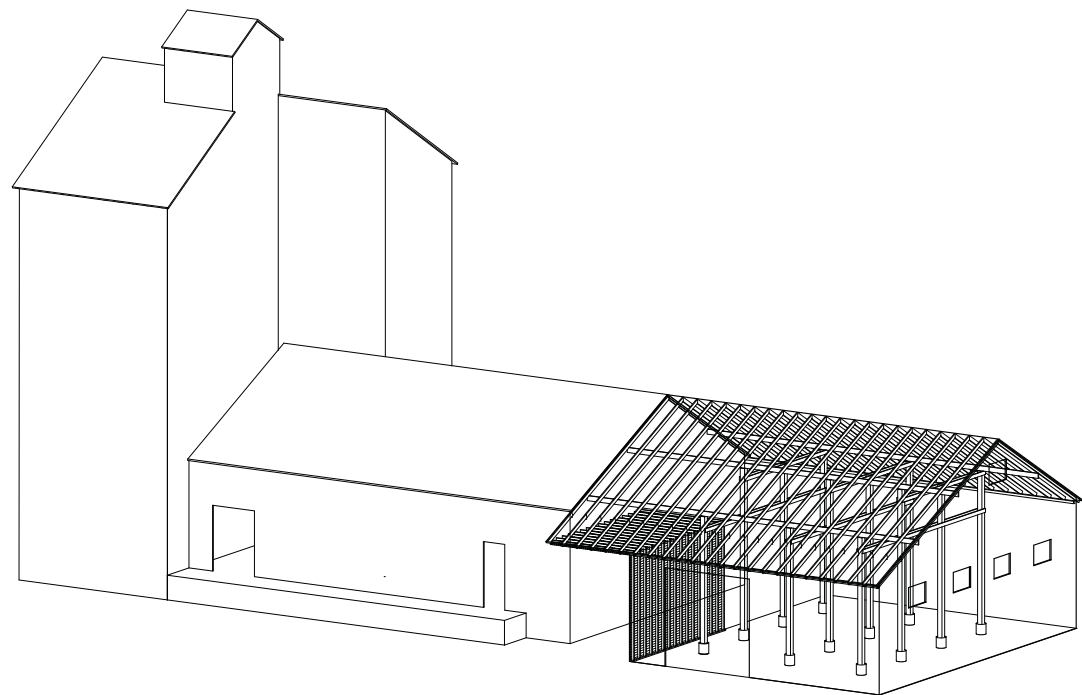
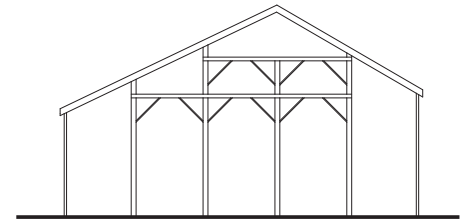

The final shed addition to the south of the tower has a similarly densely packed wood truss roof system, but with alternating truss shapes which provide an interesting ceiling condition from below. This larger shed has almost 50 foot clear spans underneath and runs 85 feet in length, again providing maximum flexibility.

34. The final shed addition has a column-free space spanned by alternating timber trusses

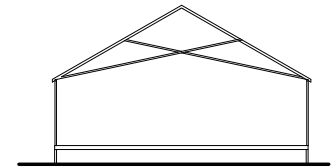
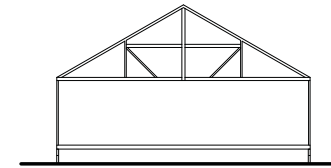
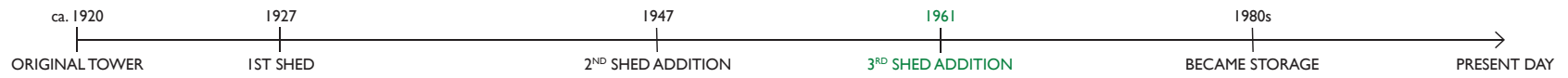

50' SPAN

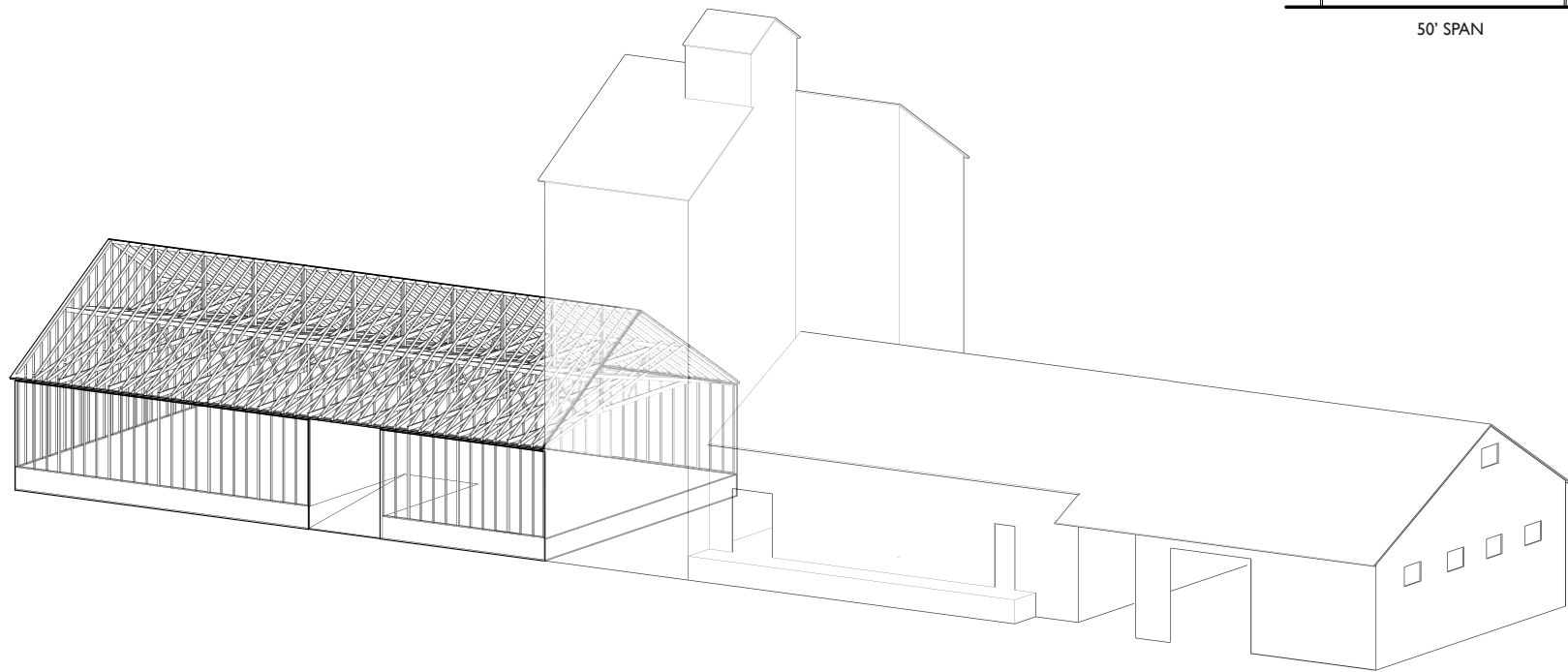

[PROGRAM]

The primary function of this new facility will be an artisan cheese creamery. The craft of cheese making is one steeped in tradition, and the enjoyment of artisan cheeses can be very rich and multi-sensory. With that, and the connection to all of the local dairies, this has the potential to create a rich experience for a visitor as they interact with the making and tasting of cheese, and then visually reconnect to its local agricultural origin. The addition of supplementary programs will further enhance the visitor's enjoyment and understanding of cheese. First, a cheese making classroom invites people to a hands-on way of interacting with the cheese making process. A retail component is also included, including a cheese counter and shop and a small café, which encourage potential visitors into the building and of course help provide commercial viability for the creamery. Finally, the most multi-sensory portion of the program, including the aging tower, grain bin tasting rooms, and a wine & cheese pairing classroom, are located in the tower itself, interacting with the interesting vertical spaces and providing expansive views out into the landscape, providing the desired visual connection with the cheese's origins

35.

Program diagram

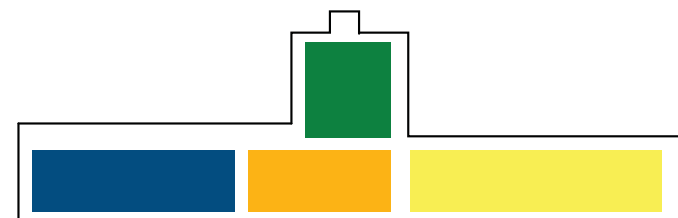

ARTISAN CHEESEMAKING

INTRODUCTION

Artisan cheese, as opposed to mass-produced cheese, is made with all natural ingredients and is produced in small batches, often using traditional production techniques.²³ Washington State is home to a large number of artisan cheese makers. Located at the Pike Place Market in Seattle, Beecher's Handmade Cheese makes the artisan process readily available to the large audience of visitors there. However, it lacks a direct physical connection to the land where the milk is made. Samish Bay Cheese in Bow, WA is an example of a farmstead cheese maker. They raise their own cows, milk them, and make the cheese on site. Farmstead cheese making is of course very connected to the land, but is limited in production and audience to their own farms, and often cannot support high visibility of their cheese production.²⁴

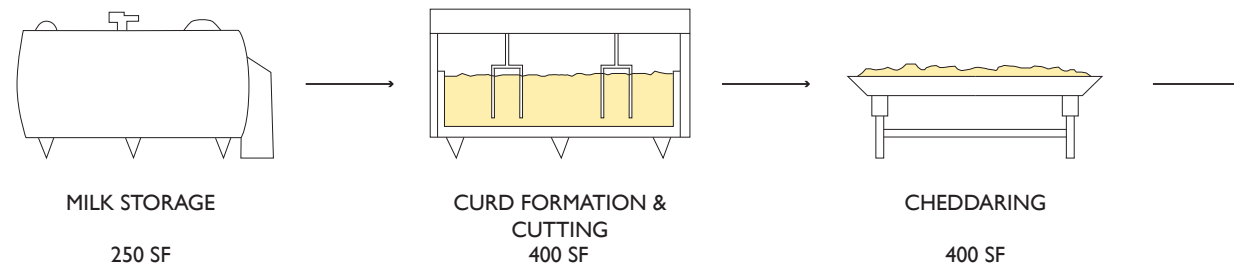

36. Artisan cheese-making process

²³ Sustainable Farming Association of Minnesota. Artisan Cheese Making. 2013. <http://www.sfa-mn.org/work/artisan-cheese-making/> (accessed June 11, 2013).

²⁴ Beecher's Handmade Cheese and Samish Bay Cheese companies are both members of the Washington State Cheesemakers Association; these companies were chosen as examples which primarily use cow milk (as opposed to goat, sheep, buffalo, etc.). More information can be found at: <http://www.washingtoncheesemakers.org/members.shtml>

BASIC PROCESS

There are four basic steps to cheese making, which are altered slightly to produce different varieties of cheese. First the milk must be pasteurized, unless the cheese will be aged for over 60 days; then the milk can be raw. Next is the formation of curds, also referred to as cheese making. In an open vat, often called a Make Vat, ingredients are added to the milk, curds form and are cut into cubes. This process releases the whey. Next is cheddaring: the curds are pressed, cut into loaves, stacked, and left to drain more whey. Salt and flavorings are also added at this point. The final step before aging is called hooping. Curds are placed in molds called hoops, and pressed with a cheese press.²⁵

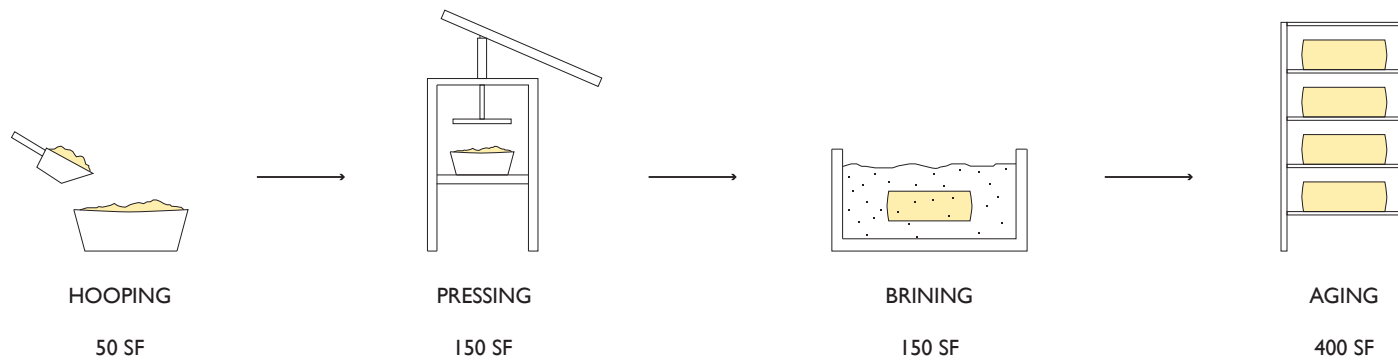

²⁵ Beecher's Handmade Cheese.

GOUDA

This facility is designed for the production of several varieties of Gouda cheese, though it remains flexible enough to accommodate many other varieties. This popular cheese originates from Holland, but is made all over the world. Made from cow's milk, this cheese gains its unique sweet flavor due to the removal of some milk sugars early in the process. After the curd has formed and has been cut, about one third of the whey is removed, which limits excess acid produced by the bacteria culture. Hot water is added to replace the whey, which heats the curd. After the curds have been pressed into molds, the cheese is brined for about 24 hours. The traditional wax rind is added after the cheese is dry to the touch.

Gouda needs to age at least 60 days, and can be aged for up to 4 years. The longer the cheese is aged, the drier, harder, and stronger tasting it becomes. The climate control requirements for aging Gouda are 56-64 degrees F, and 80-85% relative humidity. Due to the Pacific Northwest's temperate and wet climate, this should be possible with a relatively simple climate control system. Other methods of modifying the cheese include smoking and the addition of spices or herbs. With a focus on Gouda cheese, but with a delicious variety possible through varied aging times and other modifications, the creamery can offer a high quality range of products.²⁶

²⁶ New England Cheesemaking Supply. Gouda: A Cheese from the North Country. 2012. <http://www.cheesemaking.com/Gouda.html> (accessed June 11, 2013).



37.

Handmade Gouda cheese from Holland

KEY SPACES

As this is a manufacturing facility, there are many technical space requirements that will be accommodated within the building. However, in following the prerogatives outlined in the theoretical framework, this thesis seeks to accomplish more than designing an efficient place to make and sell cheese. This facility will bring artisan food makers and the general public together, in a building deeply connected to the local agricultural landscape, to engage in a process of food production. In this way, the grain building once again becomes a node within the local food production network, which can then distribute the food into larger networks. In order to help reconnect the public with food production, this process will be made highly visible. The program can be divided into four categories: make, shop, learn, and experience.

MAKE

The creamery, as the production space, contains the most constant activity. Here, the main steps of cheese making occur: the separation of curds and whey, cheddaring, hooping, pressing, and brining. These main activities need to be contained, as they create an abundance of excess heat and moisture, and also must have sterile air conditions. The primary user is the cheese maker, but visitors will have good visual access to the process. Important technical adjacencies include the raw milk room, cooler, dish washing station, dry ingredient storage, and aging room.

SHOP

The retail component of the program includes a cheese counter, located near the entrance of the building, where visitors can purchase the cheese made on site. The shop could also include other local food products as the local food community grows. A small cafe is also located on the ground floor, featuring recipes which include the creamery's cheese.

LEARN

The cheese making classroom, located on the ground floor, is a large open space filled with enough large tables to accommodate classes up to twelve people. Here, visitors can sign up to take a handmade cheese course, during which they would make several fresh cheeses at individual stations. When the tables are cleared away, the space becomes a flexible event space.

EXPERIENCE

This category encompasses all of the functions housed in the tower: the aging elevator, cheese tasting classroom, and grain bin tasting rooms. The aging room, though of course part of the cheese making process, is included in the experiential part of the building. This will bring visitors in close contact with the culmination point in the process of making cheese. The cheese tasting classroom and grain bin tasting rooms take on the spatial character of the interesting spaces of the existing tower. The tasting of the cheese coincides with the best views of the landscape and spaces with the most dynamic relationships with the remnant grain bins, which heightens the tasting experience.

USERS

The daily users of the new facility will be, of course, the cheese makers themselves. The artisan cheese makers who will work in this facility are passionate about cheese and sharing their knowledge and products with the public. They will work within the make space.

The shop, learn, and experience components are designed for visitors to the facility. Potential customers at the creamery may range from very enthusiastic supporters of artisan cheese making to curious people passing through the town. In each case, the building will engage them in the process of cheese making, encourage interaction between customers and cheese makers, and make clear the connection between the creamery and the surrounding working landscape. The building should be inviting while maintaining its utilitarian character, functioning more as a node of production which may be occupied by the public, as opposed to a token tourist attraction.

In addition to their potential participation as visitors, Silvana community members will garner additional benefits. The grain building, once such an important and busy part of the town, currently stands as a silent, mysterious monument to an unfamiliar past. Once reactivated, the facility will promote new daily activity both on its grounds and in the small town.

A number of activities are available to visitors. Guided tours through the entire facility will be available. More casual visits, to the shop or the cafe, are also encouraged. Cheese making classes will be offered evenings and weekends, while cheese tasting can occur during creamery hours or during reserved times after hours. In addition, the entire space could be rented for private events, such as a wedding. By incorporating activities for different times of the day and week, for different interest levels, and varying durations, this facility will be active and full of life.

[DESIGN RESPONSE]

This new facility will allow for a deeper understanding of food production and will reestablish the existing building's connection to the larger network of agriculture in the area. The integration of an artisan creamery into this agricultural community will allow visitors to see beyond the pastoral scenery of the place and recognize it as a working landscape: the source of our food.

Architecturally, the building celebrates its utilitarian beginnings, yet acts as a beacon for a new positive and integrated function in the landscape. Interventions and additions are made based on the evaluation of the existing building and site as outlined in the methodologies section.

38. Proposed facility from across the street,
drawing people in with new activity



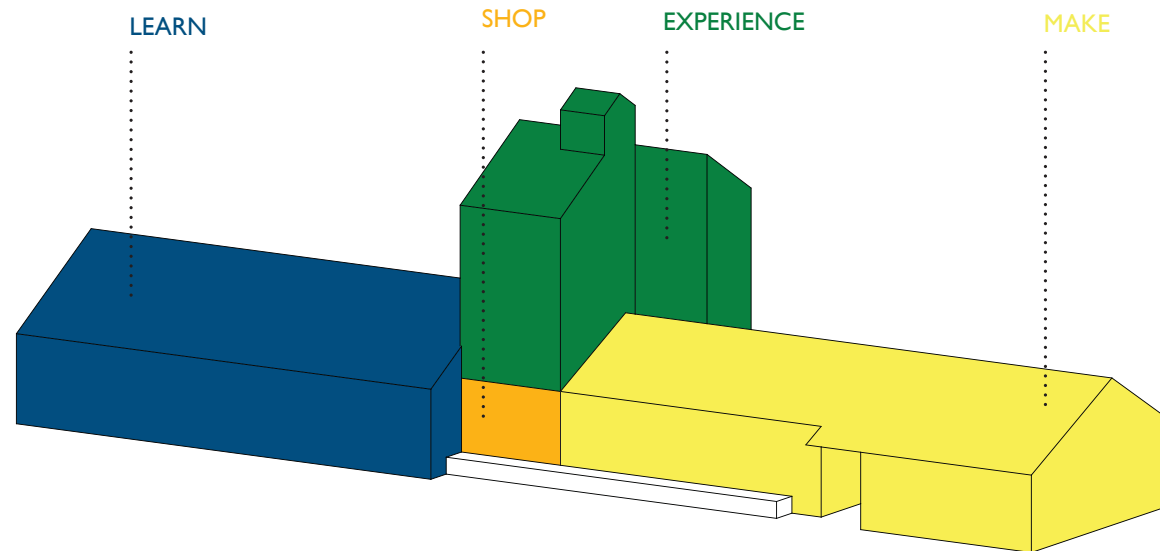

39. Program allocation based on structural, spatial, and site characteristics

PLACING PROGRAM

A combination of site relationships and adaptive reuse strategies come together to determine the placement of program within the building. The qualities of the various components of the existing building make them predisposed to work for different parts of the proposed program. Firstly, the column-free space within the shed structures makes it ideal for inserting the creamery, as this requires a large amount of flexible space. The creamery is inserted into the north shed, adjacent to the parking lot, for easy access for delivery and shipping, and to ensure that every visitor is drawn past the make room as they enter the facility.

INTERVENTIONS

As previously discussed, the key to a successful adaptive reuse project is to capitalize on the existing building's strengths and minimize any weaknesses, while optimizing the space for the new intended function. After analyzing the existing conditions, certain interventions are proposed which will both facilitate the building's new purpose and simplify and elucidate the existing structure, creating a legible and functional structure.

40. Exterior interventions to the existing building

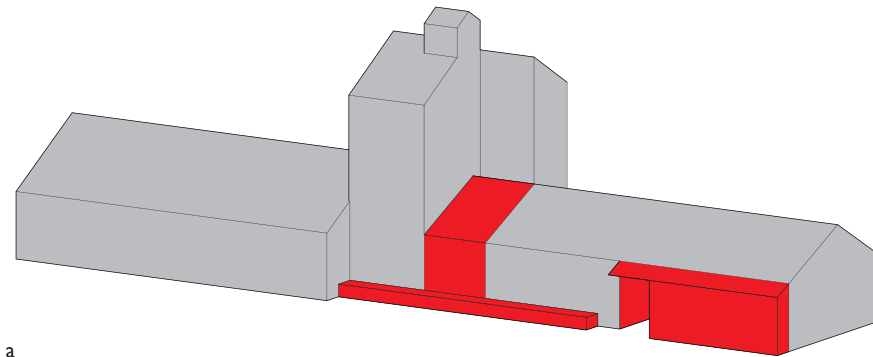

a

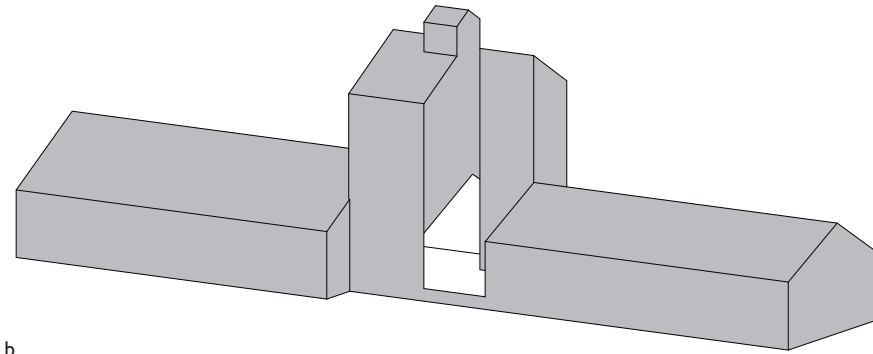

b

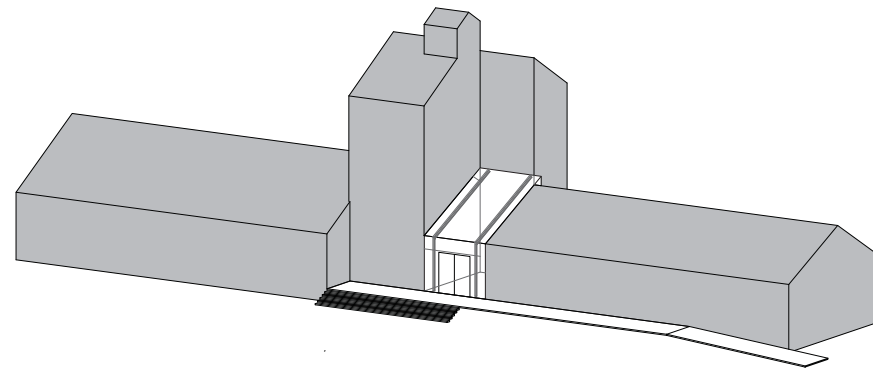

c

EXTERIOR INTERVENTIONS

As diagram 40-a shows, the first step is to remove the parts of the structure indicated in red. At the end of the north shed, the end of the gable is removed in order to create a simple, streamlined shape; unifying the two construction types within the shed (see figure 40-b). The second piece to be removed is the structure at the junction of the north shed and the tower. In its current state, the relationship between the roof trusses of the shed and the heavy timber construction of the tower is messy and haphazard. By removing it and creating a void at the center where the shed and tower come together, a space is created where one can stand and better appreciate the relationships between the varying construction types as well as the contrasting horizontal and vertical spaces.

Next, a wide, ramping deck up from the parking lot is added along the street side of the building while the new void is covered with a simple glass insertion. In this way, an entry sequence is created, drawing people up past the creamery space and into the center of the tower. The glass insertion conforms to the silhouette of the building, but is built with simple steel construction, differentiating itself from the existing building and thus creating an interstitial space of entry (figure 40-c).

As discussed, the current cladding system for the building is simple – corrugated metal panels attached directly to the wood studs. This thin envelope is of course inadequate now that the building is intended for human occupation. As the wall is thickened to include insulation and interior finish, it is still important to maintain a simple material palette and silhouette drawing from utilitarian agricultural buildings on the exterior. While the

40. (continued) Exterior interventions to the existing building

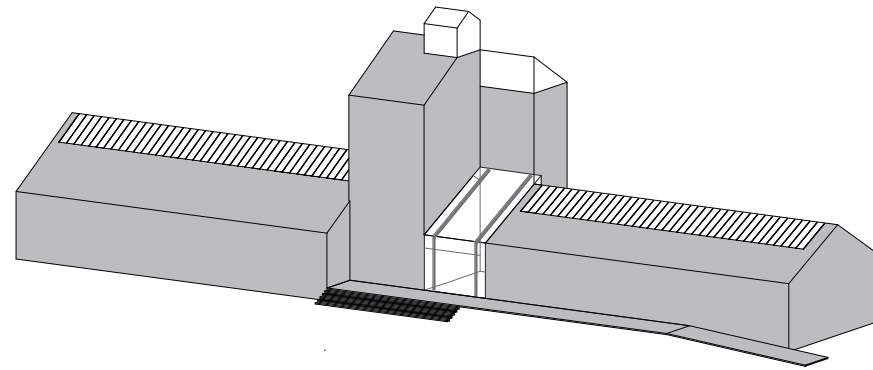

d

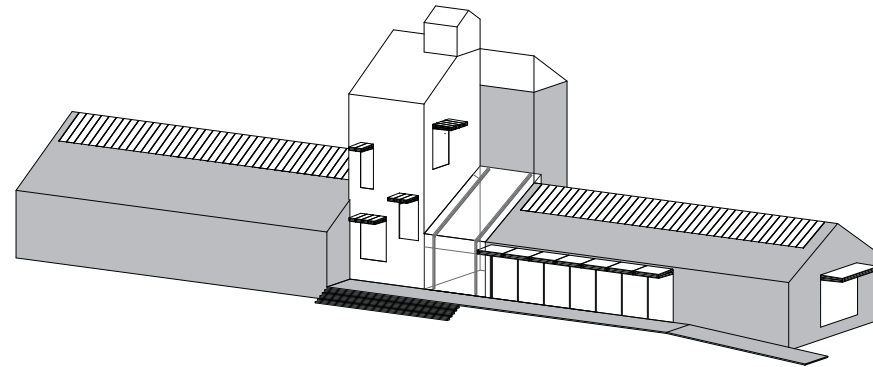

e

41. Exterior cladding materials - corrugated metal, corrugated polycarbonate, corrugated perforated metal

building is still clad in corrugated sheets, different materials and operability are introduced, allowing for daylight, views in and out, and a dynamic and porous building envelope. First, using corrugated polycarbonate panels, operable skylights are introduced along the north sides of the shed ridges for indirect daylighting and ventilation, and the tops of the tower become daylighting cupolas which can act as beacons at night. This can be seen in Figure 40-d.



Then a system of shutters is introduced, made from perforated corrugated metal panels on a hinging framework, which fold up to create sheltering and sun shading overhangs. Each window has an accompanying shutter, allowing visual connections to be made from interior to exterior when open, and filtered light when closed. Each opening is carefully placed. One long bank of windows with accompanying shutters opens along the creamery façade, creating visual connections between inside and outside and acting as a storefront. In the classroom, another linear bank of windows opens out to the fields, creating connections in that direction and opening to the south for passive heating. In the tower, each opening is associated with a landing on the stairs, or with each tasting room and their framed views of the landscape. (Fig 40-e)



The main tower is completely clad in a new layered envelope system made of an inner translucent material, which is then screened by the same perforated corrugated metal found on the shutters. This translucency enables the inner structure to be silhouetted behind the façade, hinting at the spaces within when viewed from outside. The effect would be especially pronounced at night, causing the tower to become a beacon within the valley. (Fig 40-e)

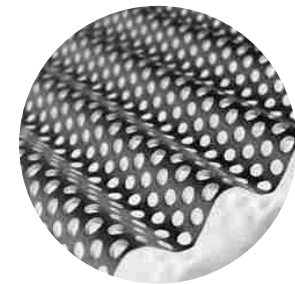

42. Interior interventions to the existing building

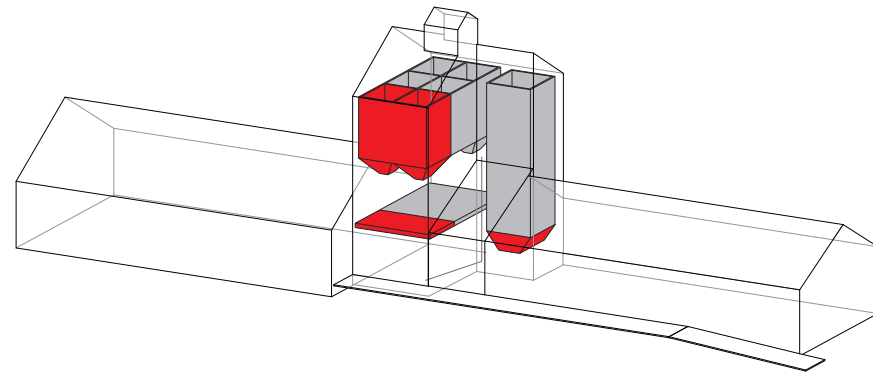

a

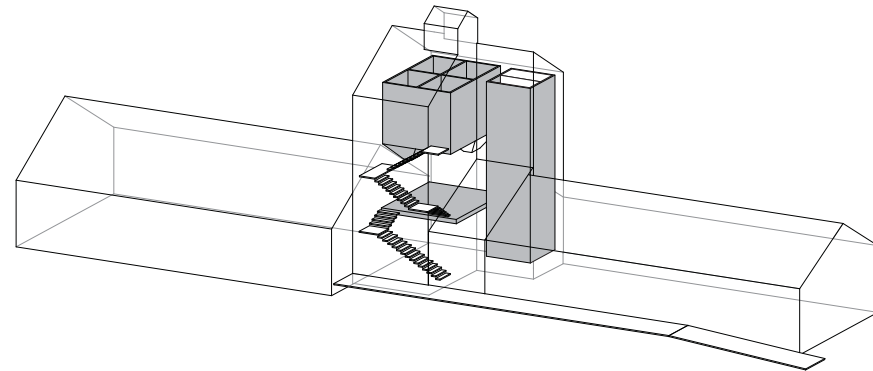

b

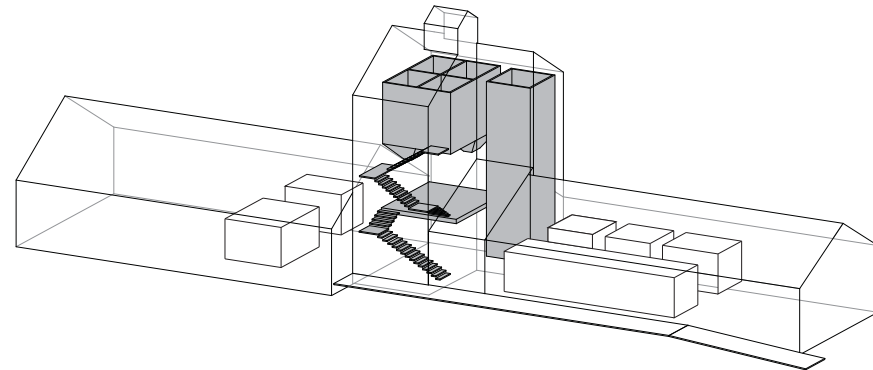

c

INTERIOR INTERVENTIONS

Next are the interior interventions, which both house program and facilitate movement and connections between the different elements in the building. First, in order to allow movement up through the tower, two of the existing bins are removed, as well as the hopper portion of the large, full height bin (pictured in red in figure 42-a). This creates the opportunity for circulation within the tower, bringing people up to interact with the structure and to facilitate the desired views out to the landscape. Stairs are located at the front of the building, to draw people up as they enter building, and to be seen through the new semi-transparent and opened façade from the street. A lift is added in the full height bin as well along with the aging space for the cheese, which will be explained in greater depth in the following section. These insertions can be seen in Figure 42-b.

Finally, self-contained elements are introduced within the shed structures, each of which houses new program functions (shown in Figure 42-c). In the north shed, each box contains different parts of the creamery, including the make room towards the street front, then dish-washing and cold- and dry- storage rooms towards the back. Each function is housed in separate glass enclosures, as they require sterile air-handling, and in the case of the make room and dish-washing room, have hot, humid environments that should be kept away from other functions. In the south shed, the boxes contain the café kitchen, storage for the classroom tables, and the rest rooms. These boxes also float free of the primary shed structure, and help divide the space between the café and classroom. This strategy of enclosing spaces separate from the primary structure emphasizes the flexibility and freedom that the column-free sheds provide.

- 1 FROM PARKING LOT
- 2 PAST CREAMERY
- 3 UP CHEESE AGING LIFT
- 4 THROUGH BIN TASTING SEQUENCE
- 5 DOWN TO TASTING CLASSROOM
- 6 TO SHOP & CAFE

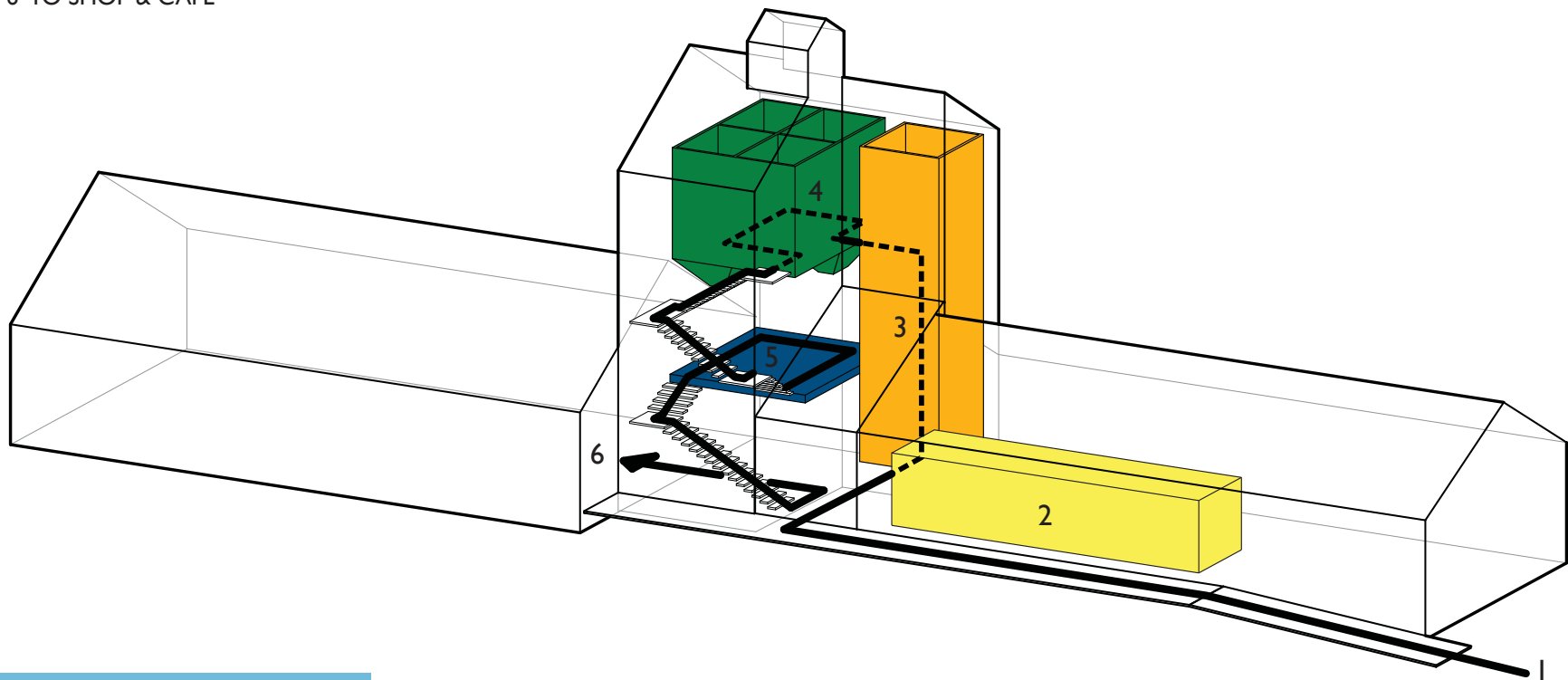

PRIMARY VISITOR SEQUENCE

The following is a description of the key spaces in the project... They are presented as a sequence which represents the most formal and complete tour of the facilities by a potential visitor. In the day-to-day operations of the creamery, there would be ample opportunity for more casual visits to any one of these spaces. Furthermore, it is intended that the classroom, café, and tower spaces could be made available for additional uses on an after-hours rental basis. However, a description of the following choreographed sequence through the building gives a complete sense of the intention of the project.

43. Diagram of primary visitor sequence, encompassing a complete and formal tour of the facility

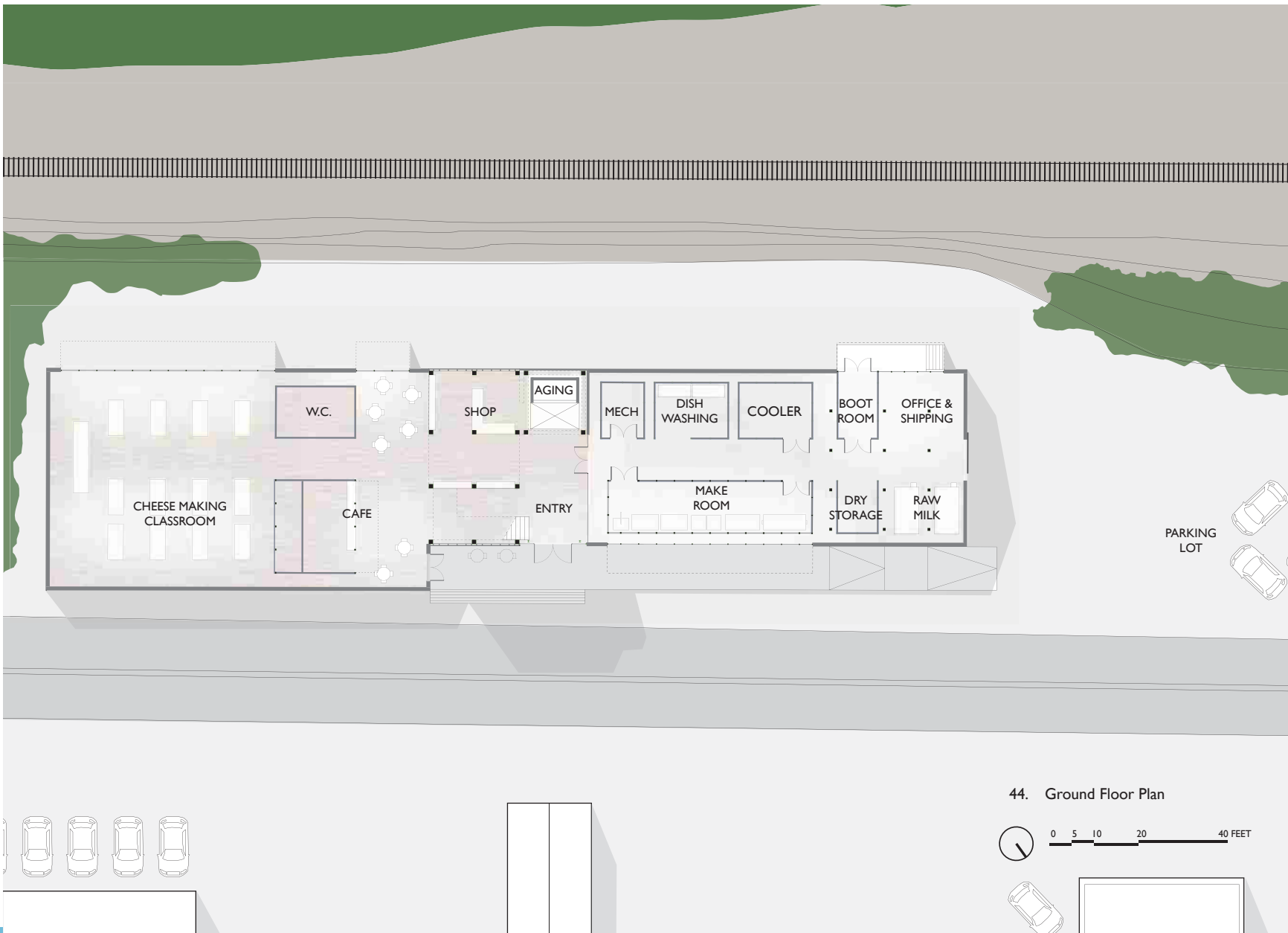

44. Ground Floor Plan

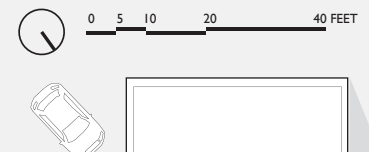

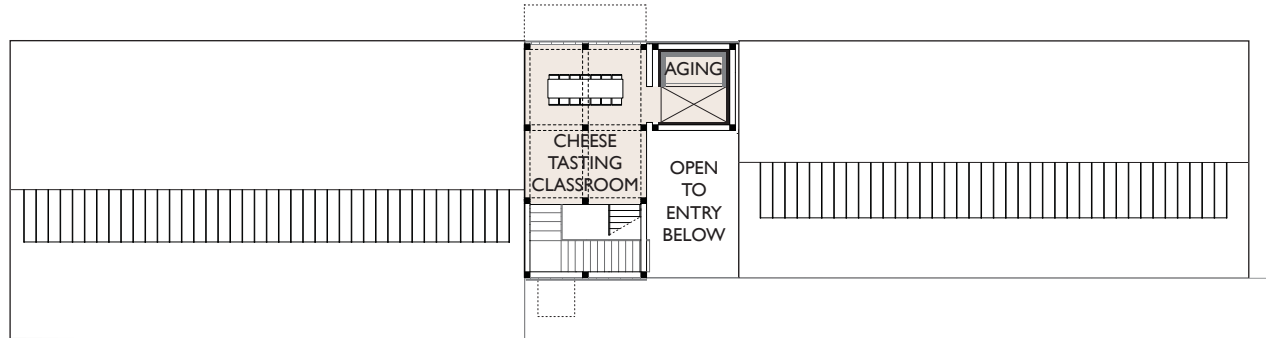
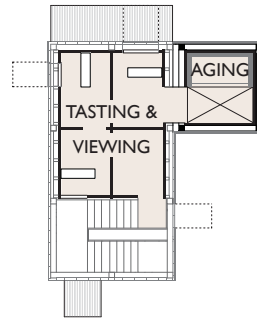

45.

Second and Third Floor Plans

PRIMARY VISITOR SEQUENCE | APPROACH PAST CREAMERY

The approach to the building sets up the first connection between the visitor and the cheese making process. As previously described, a wide deck leads from the parking lot to the entry at the center of the building. As a visitor walks along the deck, they are traveling parallel to the cheese making process inside. Large windows open along the deck for the full length of the make room, allowing visitors to observe the entire process from the separation of the curds and whey through to the pressing and brining. By situating the entry sequence this way, each visitor is made to view at least part of the cheese making process, beginning their connection with local food. Then, as a visitor turns ninety degrees to actually enter the building at the glass insertion, all of the opportunities of the facility open before them.

46. View of approach past the make room

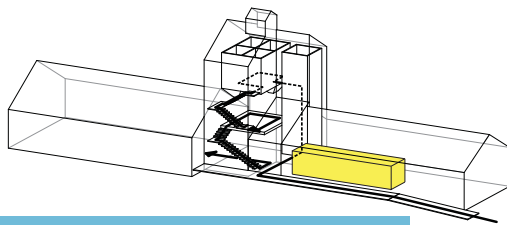



PRIMARY VISITOR SEQUENCE | ENTRY SPACE

The main entry space, the void created in the structure as previously mentioned, connects the visitor to all of the different spaces in the building, both vertical and horizontal. The creamery opens into the entry from the right, the shop and café to the left; the primary stairs extend out into the space, beckoning upward into the heavy structure of the tower. The second floor, which holds the cheese and wine pairing classroom, acts as a balcony above. As a visitor looks upward through the new glass ceiling, the full height of the tower can be appreciated. Directly ahead is the aging tower with a simple lift to take both visitors and cheese makers to the top of the tower: this is the place where the end of the cheese making process and the beginning of the visitor's journey up the tower intersects.

47.

View of main entry space

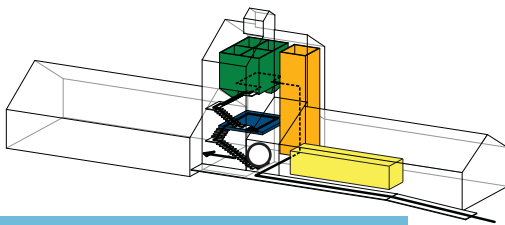



PRIMARY VISITOR SEQUENCE | CHEESE AGING TOWER

The aging tower functions as both vertical circulation space and as the aging room. While the vertical configuration of the aging room is unconventional, it does allow for other advantages. First, its double use as circulation for cheese makers and visitors creates an interesting intersection of use. It allows the aging cheese to be put on display, rather than hidden in a closed room, and is located at the center of activity in the building, establishing a stronger connection between the visitors and the last step in the cheese making process. Second, as the aging cheeses occupy a former grain storage bin, it harkens back to the building's original function as a grain elevator. By also bringing people directly in contact with the artifacts of the grain elevator, so they can feel the volume of the bin as it rises up, touch the rough wood of the bin walls, and see the light filtering down through the translucent roof far above, they can begin to fully appreciate both the history and the new use of the building.

48. View up the cheese aging tower

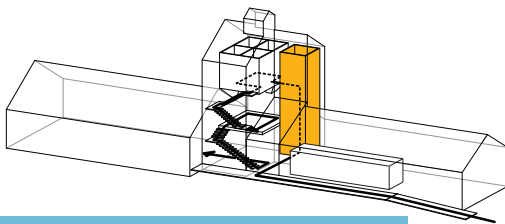



PRIMARY VISITOR SEQUENCE | CHEESE PAIRING CLASSROOM

After having passed the cheese it its final step before consumption, a visitor emerges into the cheese pairing classroom space. This space is perched halfway up the tower, on level with the intricate truss systems of each shed, and with the former grain bins hovering above. A large shuttered window opens out to the west, over the farmland, forming the first big visual connection back to the origin of the cheese as it is first tasted. As this is an open space with connections to the first floor and the activities there as well as views out to the landscape, this is envisioned as a group tasting space. In the structured tour setting, there would be classes in which a group of people could learn the subtleties of tasting cheese, and the skill of pairing cheeses with various wines, beers, and other beverages. After hours, this space could be available for private dining parties. In this group-based, social setting for tasting cheese and viewing the landscape, a stronger connection is made to the food and the setting.

49. View of cheese tasting and pairing classroom

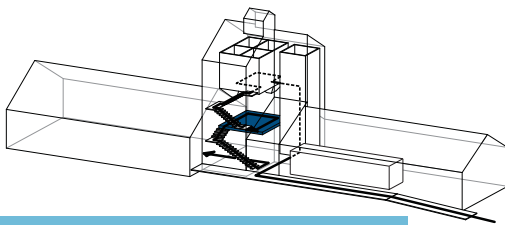

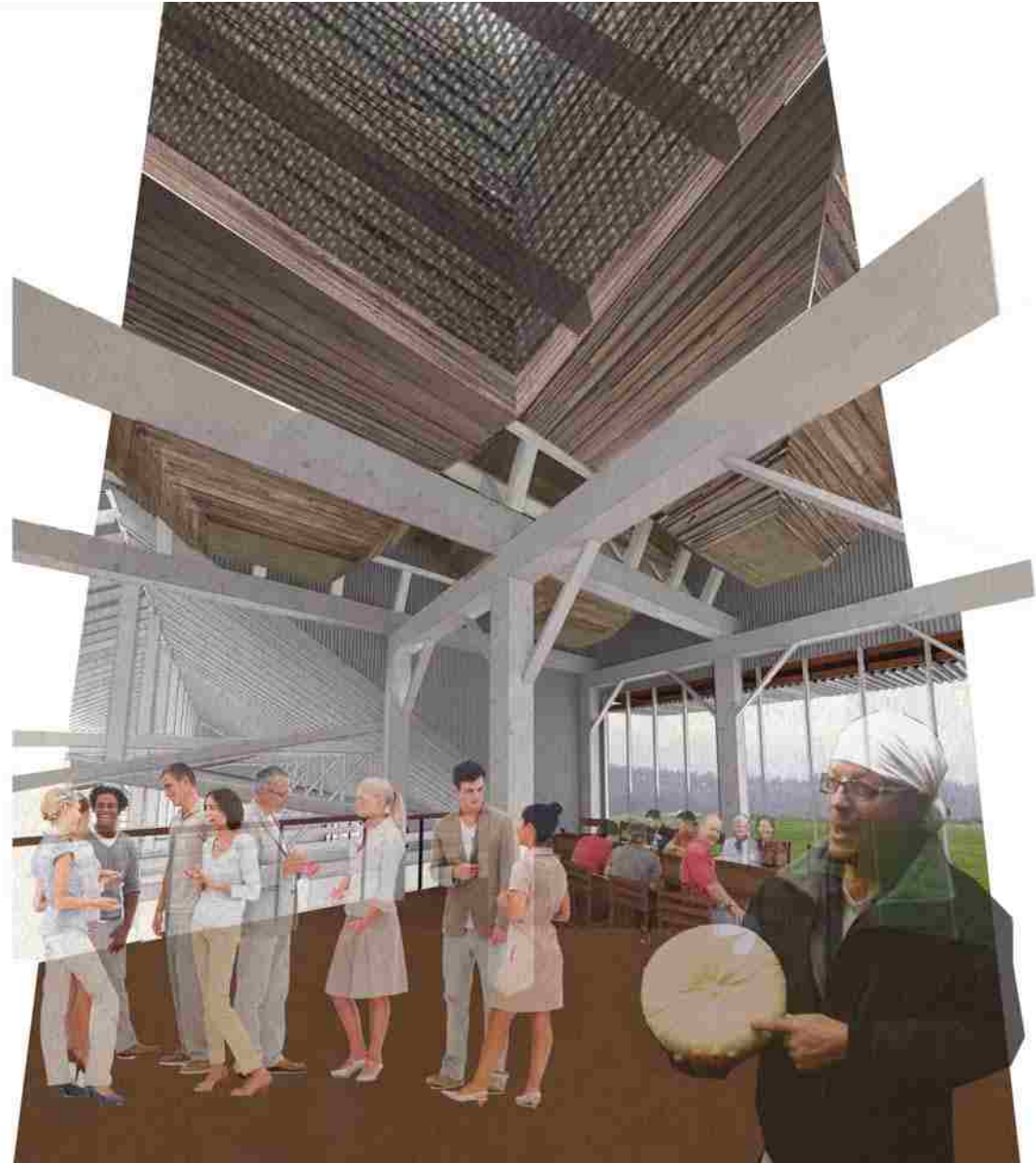

PRIMARY VISITOR SEQUENCE | BIN TASTING ROOMS

As the visitor finally reaches the top of the tower, they move inside the grid of existing grain bins for a series of intimate tasting spaces with expansive framed views of the landscape. Openings between the bins are created by simply cutting holes in the stacked wood walls with a chainsaw or similar implement; the cribbed construction allows this sort of manipulation without any significant loss in structural integrity. The cuts very simply expose the construction of the bins while allowing movement in between. This last experience, with the smallest space and the most expansive view, where a person can quietly taste cheese and look out on the beautiful working farmland, reinforces the entire facility's intention that people can reconnect with the realities and joys of food production.

50. View of tasting room inside a grain bin

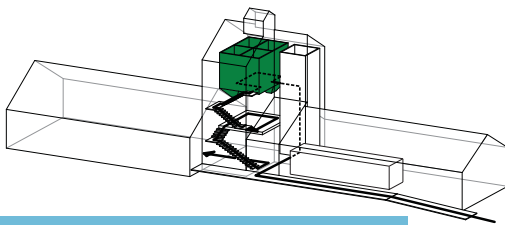



51.

Cross section through cheese making
classroom

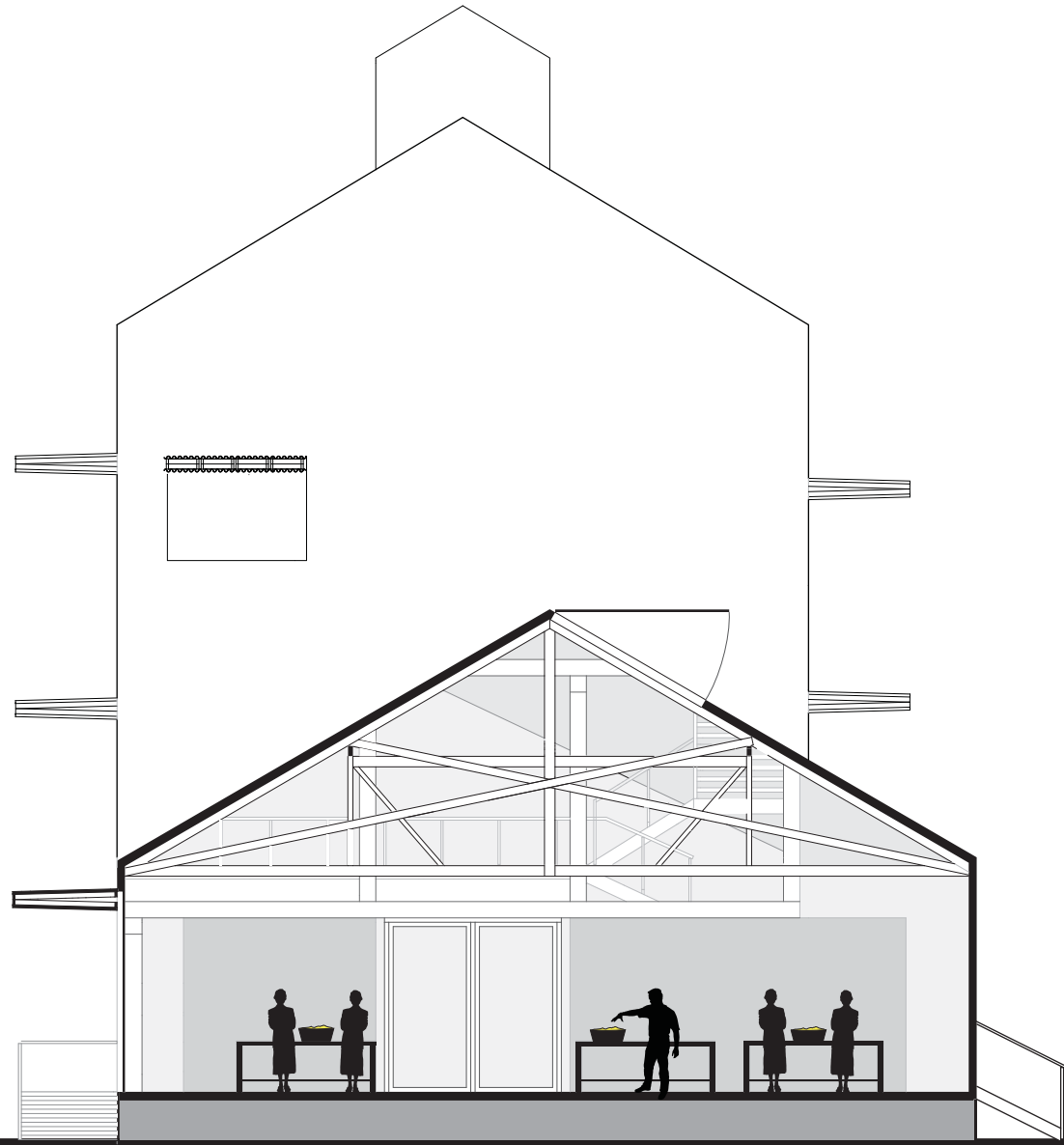

52. Cross section through the tower, including the shop on the ground floor, cheese tasting classroom on the second, and bin tasting room on the third.

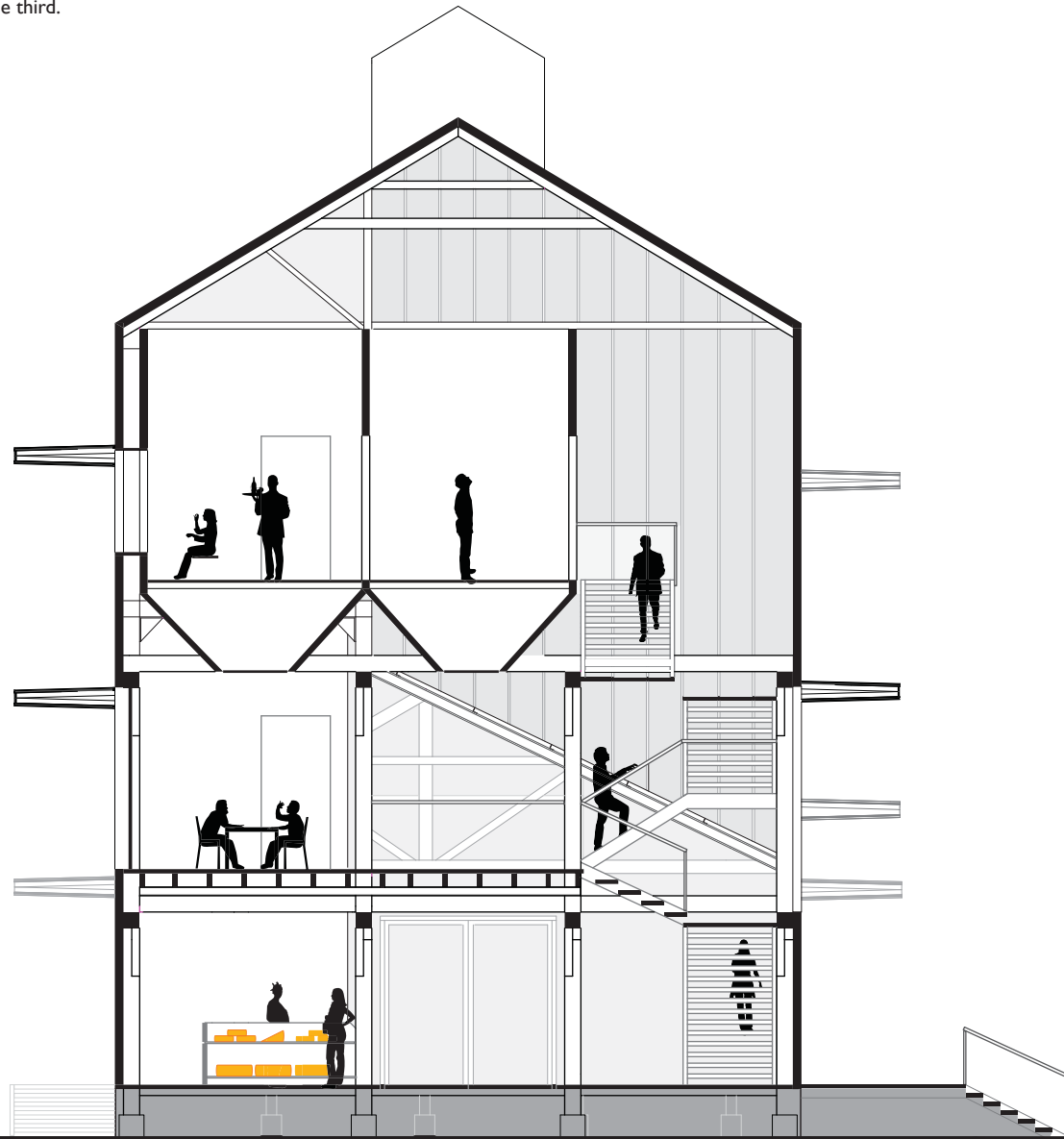

53.

Long section through entire building

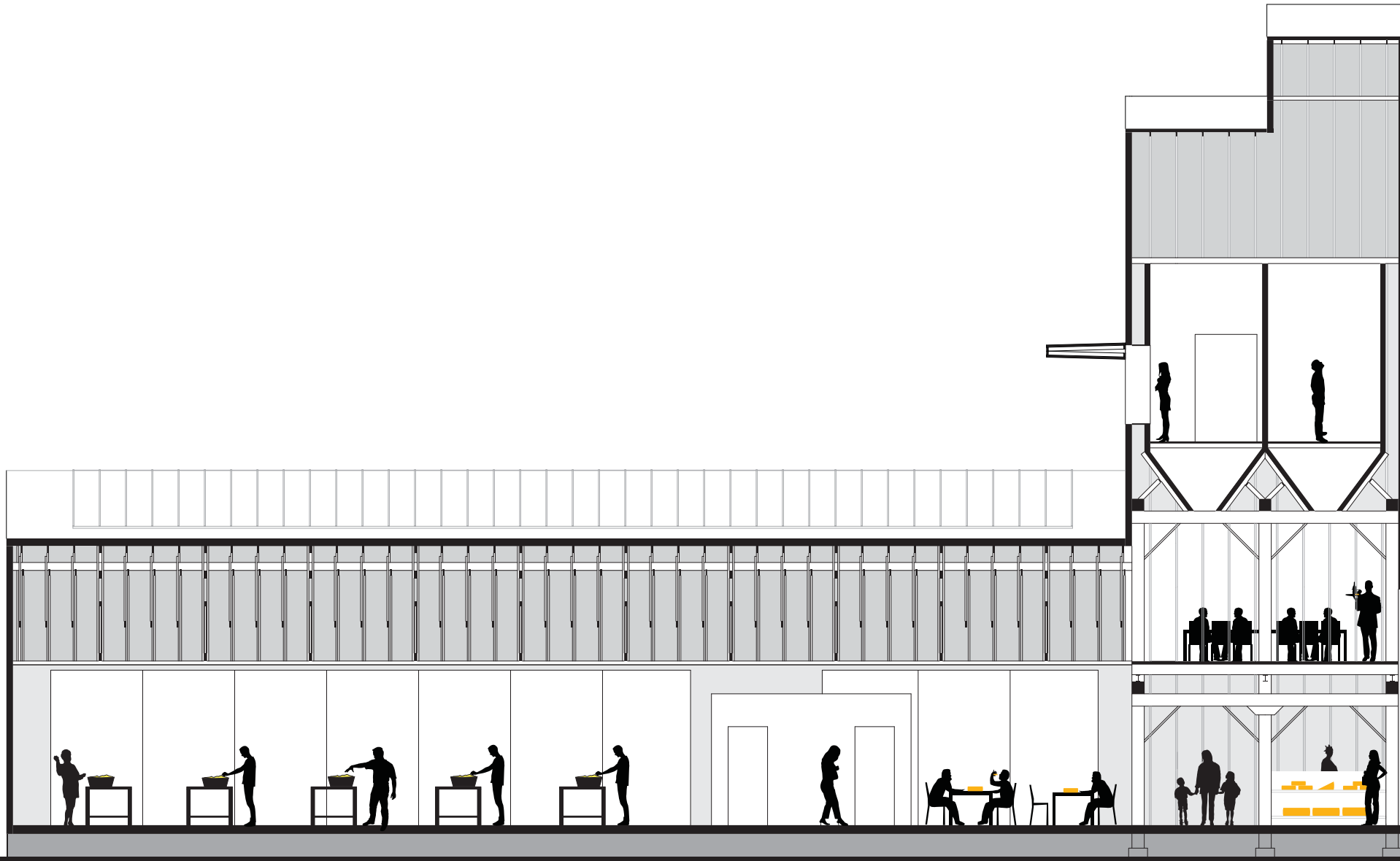



54. Cross section through entry space and cheese aging tower.

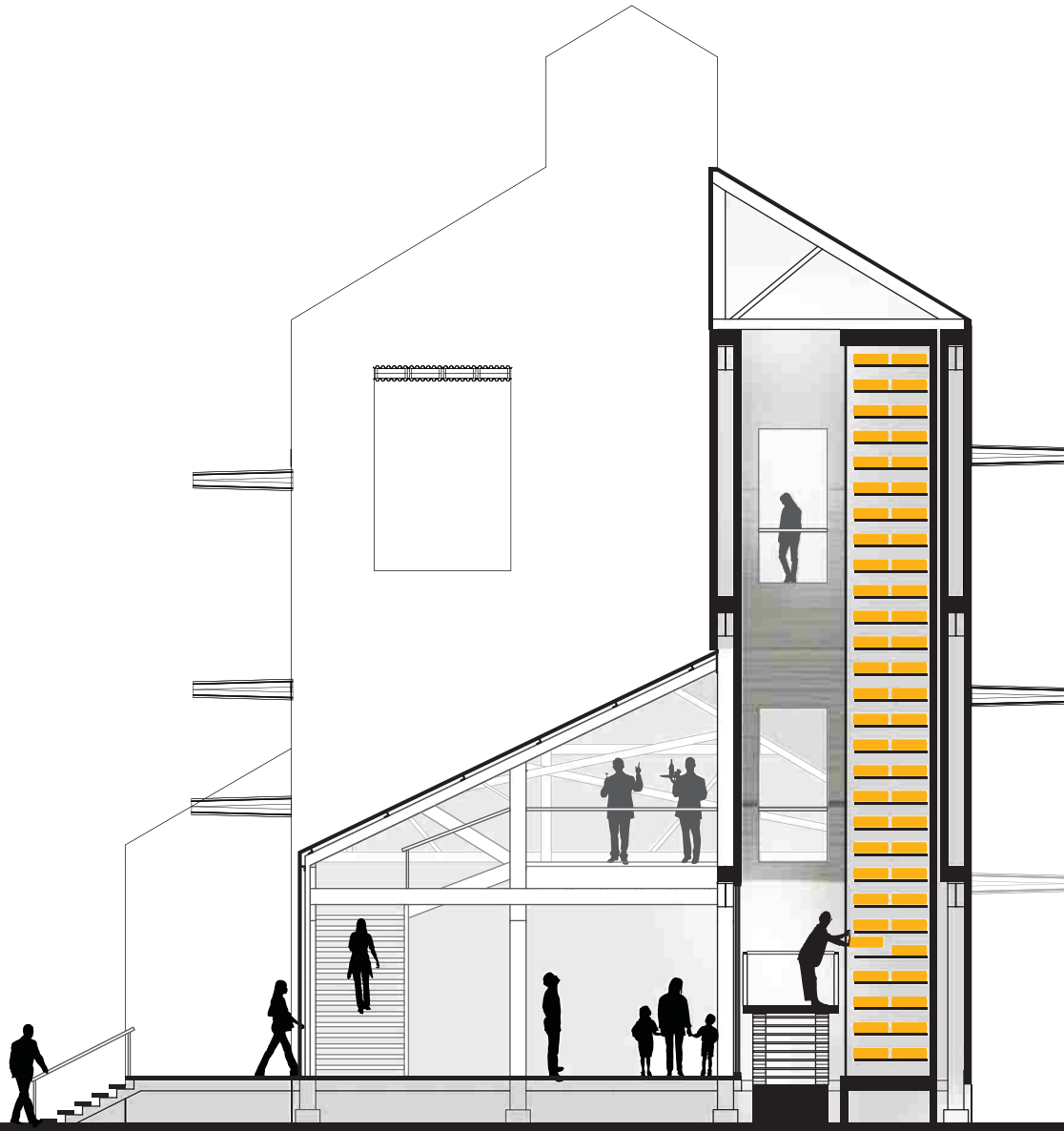

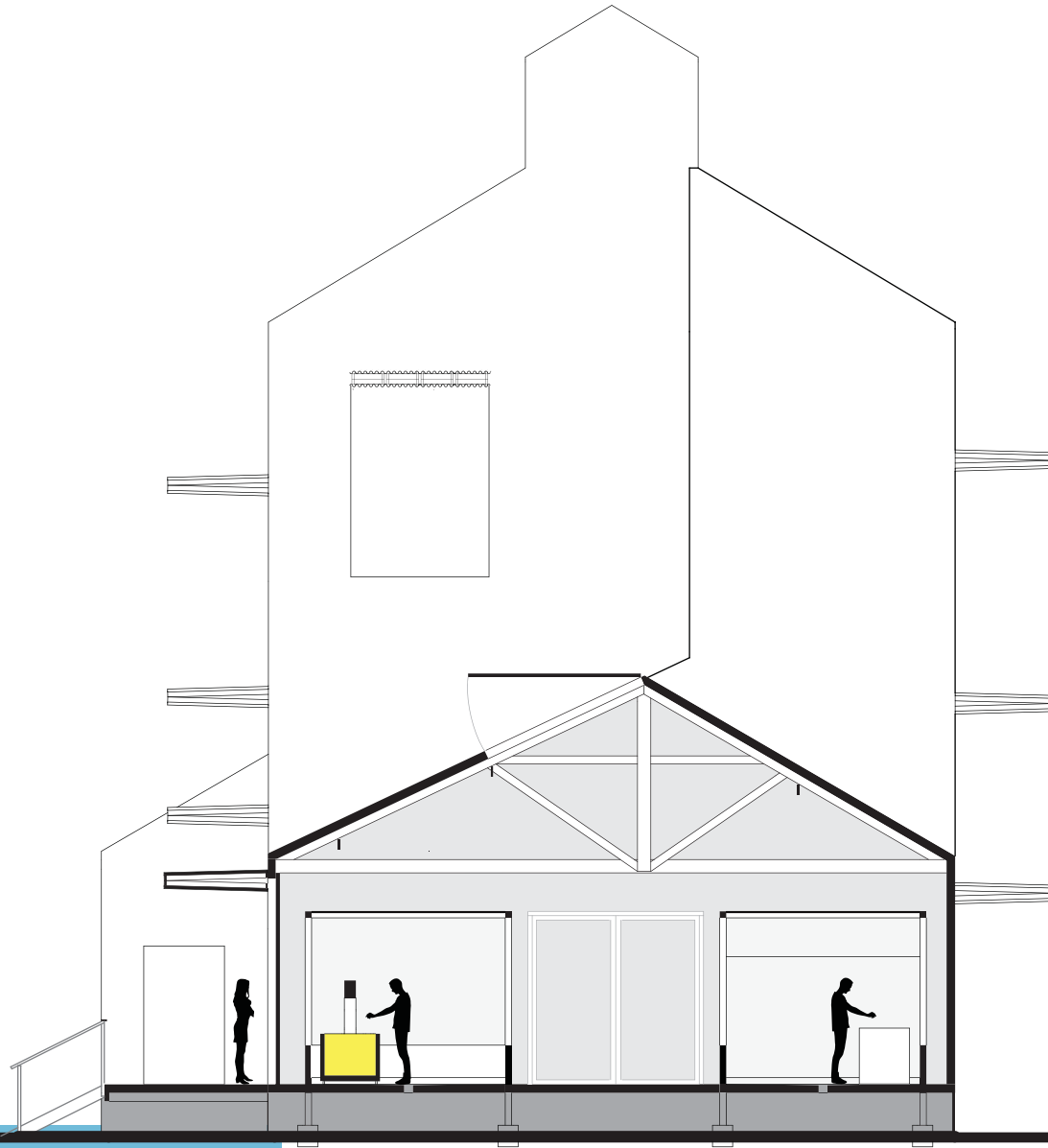



56. View of proposed facility at night from across the fields

[CONCLUSIONS]

While small towns like Silvana exist primarily due to agriculture, and though farming still exists in these places today, the majority of people in this country are completely separate from the realities of farming and food. The objective of this thesis is to create a facility in the community which promotes local food and facilitates connections between the agricultural landscape and the food we eat, on regional and local scales.

One beginning point for this project was a fascination with the Silvana Grain Company Building and its potential for reinvigorating the town of Silvana. The adaptation and reuse of our existing building stock is an obligation and opportunity for this generation. A large challenge in working on this thesis arose from the difficulty in deciding on a definite “attitude” towards the adaptive reuse of this grain building. This partly derives from the strong belief that each building to be reused is unique, and that the most important step of the process is to evaluate each building for its potential existing spaces and qualities. This is underscored by the idea that the more of a building that can be reused as it exists, the less new material needs to be brought in to the project. However, another important piece of adaptive reuse is the execution of bringing new and old together in a functional and expressive way. This project works towards this idea both at the insertion of the new glass entry space, as well as the way the new staircase interacts with the tower structure

Other considerations for continuing to develop this project include the relationship between the proposed project and its immediate surroundings. While much thought was put into both the way the people within the building would look out into the landscape, and how the building would act as a sign, symbol and beacon within the valley and town,

a next iteration could explore the immediate indoor/outdoor relationships with both the farmland and the town. Early design concepts included a terrace and greenhouse; perhaps a comparable outdoor space could be reintroduced to the project. Similarly, while the project interacts with community activities, such as a farmer's market, the Silvana Fair, and the Harvest Jubilee, this could continue to be developed with more specificity.

Another entry point for this thesis was a desire to bring design-based problem solving skills to the problem promoting local food in a small town. In many ways, this thesis could have real ramifications for the community of Silvana and the future of the Silvana Grain Company building and other agriculture-based small towns. Federal grants, such as the "Our Town" grant from the National Endowment for the Arts, exist for the express purpose of supporting small towns in the arts in order to revitalize their economies and communities. If some version of this project is to move forward, an in-depth look at the economics of the project, including potential grants such as this, would need to be completed. Even more important would be gaining the community's interest and engagement. This could begin by working with the local organization Port Susan Food and Farming Center, which already has strong ties to the local food community.

While this project could be further developed to pursue implementation, grant applications, and financing, it addresses the goals of the thesis by exploring ways that a building can promote and facilitate the proliferation of local food, the understanding of agriculture, and a sense of community in a rural place.

[APPENDIX A: PRECEDENT STUDIES]

The following precedent studies inform the design strategies in this reuse project. The first project, an olive oil factory in Portugal, combines a production facility with a connection to a rural productive site. Second, a winery in Washington state creates a place where artisan production and tasting come together. Also, the spatial relationships between the production spaces and public spaces encourage thought about the making process. Finally is a rural creamery in Doty, Washington, which utilizes an old dairy barn as their cheese making facility. This creamery was used to model production scale and equipment layout for the proposed facility.

57. Silvana Grain company building in the context of town





58.
59.
60.

Marmelo Mill, delivery
Marmelo Mill, transparency of process
Marmelo Mill in the olive orchard

MARMELO MILL

Designed by architect Ricardo Bak Gordon, this olive oil factory is located in Ferreira do Alentejo, Portugal. Built in 2010, this building exemplifies the connection between the land of production and the place of manufacturing. Sited directly in the olive grove, the building achieves a strong physical and visual connection between the raw material and the finished product. The movement of the olives as they are delivered and transported into the factory is clearly showcased by the architecture. A cantilevered canopy creates a transition from outside to inside, under which the olives are moved via open conveyor belts.²⁷ While this is clearly a new facility, as opposed to a reuse project, the principles of transparency of process and the integration into the agricultural landscape was an influence on this thesis.

²⁷ "Marmelo Mill / Ricardo Bak Gordon." *ArchDaily*. November 23, 2011. <http://www.archdaily.com/18641> (accessed June 11, 2013).





- 61. Novelty Hill Januik Winery, view from public space to barrel storage
- 62. Novelty Hill Januik Winery, view from barrel storage to tasting space



NOVELTY HILL JANUIK WINERY

Located in Woodinville, Washington, the Novelty Hill Januik Winery is a regional example of a building which celebrates growing and working with food. Designed by the Seattle based firm Mithun, this winery incorporates a production floor and barrel aging area as well as extensive entertaining spaces for the public. This mixing of production and public use invites customers to more fully understand winemaking as process and artistry, much as this thesis seeks to do with cheese making.

The treatment of the wine barrel aging room provided a relevant model for the similar facility used in making cheese. This final step, the culmination of a very controlled, artful process, connotes a quiet, patient reverence for the process and the product. The room which houses this aging product must have an ambience to support this reverence. In both cases, careful climate control is necessary for successful aging. At Novelty Hill, the integration of the technical requirements of storage with the visual display of the wine barrels is very expressive of the combination of labor and artistry required in winemaking. The very strong visual connection between the visitors and the (nearly) finished product was an influence on the treatment and placement of the aging rooms in the creamery.^{28 29}

28 Mithun. *Novelty Hill Januik Winery*. 2007. http://mithun.com/projects/project_detail/novelty_hill_januik_winery/ (accessed June 11, 2013).

29 Novelty Hill Januik. *Engaging the Ground*. 2013. <http://www.noveltyhilljanuik.com/visit/garden-design/> (accessed June 11, 2013).

WILLAPA HILLS SHEEP DAIRY AND FARMSTEAD CHEESE



- 63. Willapa Hills, milk tank room
- 64. Willapa Hills, dishwashing station
- 65. Willapa Hills Sheep Dairy and Farmstead Cheese

Located in the small town of Doty, Washington, Willapa Hills Sheep Dairy and Farmstead cheese is a family owned-and-operated artisan creamery. An extremely utilitarian make room and milking parlor have been carved out of the ground floor of an existing barn, while the hayloft above remains unused. The creamery makes and sells about 40,000 pounds of cheese per year, from the milk of their own sheep as well as a neighbor's dairy cows.

As the barn is of comparable square footage to the available space in the Silvana Grain Company Building, and because of the success of their business, it was determined that this creamery would form a good model for this thesis proposal.

While the creamery is fully functional as it exists today, the owners of course have a list of things they would change or do differently. After a tour and interview with the owners, the creamery schema for this thesis was developed by basing equipment sizing, space planning, and proposed volume of cheese production on the operations at Willapa Hills, with addenda as advised by the creamery owners.³⁰



REFERENCES

- Beecher's Handmade Cheese. Cheese Making 101. 2013. <http://www.beechershandmadecheese.com/CheesyInfo/Tips/CheeseMaking101.aspx> (accessed June 11, 2013).
- Carlson, Allen. "On Appreciating Agricultural Landscapes." *The Journal of Aesthetics and Art Criticism* (Wiley) 43, no. 3 (Spring 1985): 301-312.
- Carney, George O. "'Grain Elevators in the United States and Canada: Functional or Symbolic?'" *Material Culture* 27, no. 1 (Spring 1995): 1-24.
- Corbusier, Le. *Towards a New Architecture*. London: The Architectural Press, 1923.
- Hayes, Brian. *Infrastructure: A Field Guide to the Industrial Landscape*. New York and London: W.W. Norton & Company, 2005.
- Hutchison, Robert, and Taiji Miyasaka. "Timber Grain Elevators." *Column 5 Journal of Architecture* (University of Washington Department of Architecture) 23 (2009).
- Lowenthal, David. "European Landscape Transformations: The Rural Residue." In *Understanding Ordinary Landscapes*, edited by Paul Groth and Todd W. Bressi, 180-188. New Haven: Yale University Press, 1997.
- Mahar-Keplinger, Lisa. *Grain Elevators*. New York: Princeton Architectural Press, 1993.
- "Marmelo Mill / Ricardo Bak Gordon." *ArchDaily*. November 23, 2011. <http://www.archdaily.com/18641> (accessed June 11, 2013).
- Mithun. *Novelty Hill Januik Winery*. 2007. http://mithun.com/projects/project_detail/novelty_hill_januik_winery/ (accessed June 11, 2013).
- New England Cheesemaking Supply. *Gouda: A Cheese from the North Country*. 2012. <http://www.cheesemaking.com/Gouda.html> (accessed June 11, 2013).
- Novelty Hill Januik. *Engaging the Ground*. 2013. <http://www.noveltyhilljanuik.com/visit/garden-design/> (accessed June 11, 2013).

Port Susan Food & Farming Center. *Our Mission*. 2013. <http://www.portsusan.org/about/> (accessed June 12, 2013).

Prasse, Karen. "Stanwood - Thumbnail History." *HistoryLink.org: The Free Online Encyclopedia of Washington State History*. April 5, 2008. (accessed January 28, 2013).

Schauman, Sally. "The Garden and the Red Barn: The Pervasive Pastoral and Its Environmental Consequences." *The Journal of Aesthetics and Art Criticism*, 1998: 181-190.

Snohomish County. "Chapter 5 - Flood History." *Surface Water Management Division: Stillaguamish River Comprehensive Flood Hazard Management Plan*. February 2004. http://www1.co.snohomish.wa.us/Departments/Public_Works/Divisions/SWM/Library/F-StillyRivCompFloodHazMgmtPlan-2003.htm (accessed June 11, 2013).

Solbrig, Otto T., Robert Paarlberg, and Francesco di Castri. *Globalization and the Rural Environment*. Cambridge, MA: Harvard University Press, 2001.

Stilgoe, John R. *Outside Lies Magic: Regaining History and Awareness in Everyday Places*. New York: Walker and Company, 1998.

Sustainable Farming Association of Minnesota. *Artisan Cheese Making*. 2013. <http://www.sfa-mn.org/work/artisan-cheese-making/> (accessed June 11, 2013).

Turnbull, Amy, interview by Grace Crofoot. Owner of Willapa Hills Sheep Dairy and Farmstead Cheese (October 22, 2013).

University of Washington Libraries. *Washington History of Agriculture*. n.d. <http://harvest.mannlib.cornell.edu/node/35> (accessed June 09, 2013).

White, Richard. *The Organic Machine: The Remaking of the Columbia River*. New York: Hill and Wang, 1996.

IMAGE REFERENCES

All images created by author unless otherwise noted.

- 1 US Agricultural Stabilization and Conservation Services. Snohomish County (Wash.) Aerial Photographs: BBI-3EE-42. 1964.
- 4 Unknown artist. Pennsylvania Homestead. <http://www.mfa.org/collections/mfa-images/folkpennhomestead.jpg>
- 5 Charles Sheeler. Classic Landscape. 1931. <http://www.arthistoryarchive.com/arthistory/precisionism>
- 6 Google Maps. Slater, Iowa. <https://www.google.com/maps/preview#!q=slater+iowa>.
- 7 Glyn Baker. Chicken Farm. <http://www.geograph.org.uk/photo/219898>. Image Copyright Glyn Baker. This work is licensed under the Creative Commons Attribution-Share Alike 2.0 Generic Licence.
- 8 Ellen M. Banner. CSA Farm in Carnation, WA. Seattle Times. http://seattletimes.com/html/localnews/2008210550_farmtour28m.html?syndication=rss
- 9 Lisa Mahar-Keplinger. Grain Elevators, 23.
- 12 Rob Hutchison. Garfield Grain Elevator partially deconstructed, Garfield, WA. Timber Grain Elevators & Silos of the Palouse Exhibit, April 11th-May 2nd 2010.
- 17 Iver Botten. Logging truck outside of general store, Silvana, WA, ca. 1915. Washington Localities Collection, University of Washington Libraries, Special Collections Division. <http://content.lib.washington.edu/u/?wastate,221>.
- 18 Iver Botten. Silvana, Washington, ca. 1914. Washington Localities Collection, University of Washington Libraries, Special Collections Division. <http://content.lib.washington.edu/u/?wastate,865>.
- 22 Silvana Community Fair Board. Silvana Fair Logo. <http://www.silvanafair.com/>.
- 23 Port Susan Food and Farming Center Board. Harvest Jubilee Event. <http://www.portsusan.org/farm-tours>.
- 25 Iver Botten. Flood in Silvana, Washington, ca. 1914. Washington Localities Collection, University of Washington Libraries, Special Collections Division. <http://content.lib.washington.edu/u/?wastate,393>.
- 29 Lisa Mahar-Keplinger. Grain Elevators, 18.
- 37 Slow Family. Gouda Cheese. <http://www.slowfamilyonline.com/category/who-moved-my-cheese>.
- 41 Bridger Steel. panel_corrugated_7_8_2_white. <http://bridgersteel.com/Products/267x78CorrugatedPanel/tabid/135/Default.aspx>.
Ajoover. ajota-corrugated-polycarbonate. <http://www.ajover.co/construction/ajover-polycarbonate-translucent-roofing/ajota-corrugated-polycarbonate>.
Archi Expo. perforated-corrugated-aluminium-sheets-round-holes-61312-2030741. <http://www.archiexpo.com/prod/fielitz/perforated-corrugated-aluminium-sheets-round-holes-61312-329120.html>.

- 58 Fernando Guerra, Sergio Guerra. Marmelo Mill/Ricardo Bak Gordon (10). Arch Daily. <http://www.archdaily.com/186419/marmelo-mill-ricardo-bak-gordon/>
- 59 Fernando Guerra, Sergio Guerra. Marmelo Mill/Ricardo Bak Gordon (12). Arch Daily. <http://www.archdaily.com/186419/marmelo-mill-ricardo-bak-gordon/>
- 60 Fernando Guerra, Sergio Guerra. Marmelo Mill/Ricardo Bak Gordon (14). Arch Daily. <http://www.archdaily.com/186419/marmelo-mill-ricardo-bak-gordon/>
- 61 Mithun. Novelty Hill Januik Winery. http://mithun.com/projects/project_detail/novelty_hill_januik_winery/
- 62 Mithun. Novelty Hill Januik Winery. http://mithun.com/projects/project_detail/novelty_hill_januik_winery/

